

MOBOT® TRANSPORTER T15 mobile robot

An autonomous mobile robot for automating the transport and towing of heavy loads. Moves autonomously along a pre-programmed route.

- ▶ The perfect solution for transporting loads between halls.
- ▶ Works safely with people to transport your loads
- ▶ Increases process efficiency and reduces costs
- ▶ IP65 protection and special scanner allow outdoor use
- ▶ Interchangeable hitch gives you the option of using a variety of trolleys. You can expand the robot with a wide range of functionalities.



operating time up to 80 min on a single charge



towing capacity up 1500 kg



Wi-Fi communication



dimensions
1029 x 818 x 479 mm



max speed
5,km/h



navigation
LMS system

Intended use: for hospitals, industrial production, shops, airports, logistics

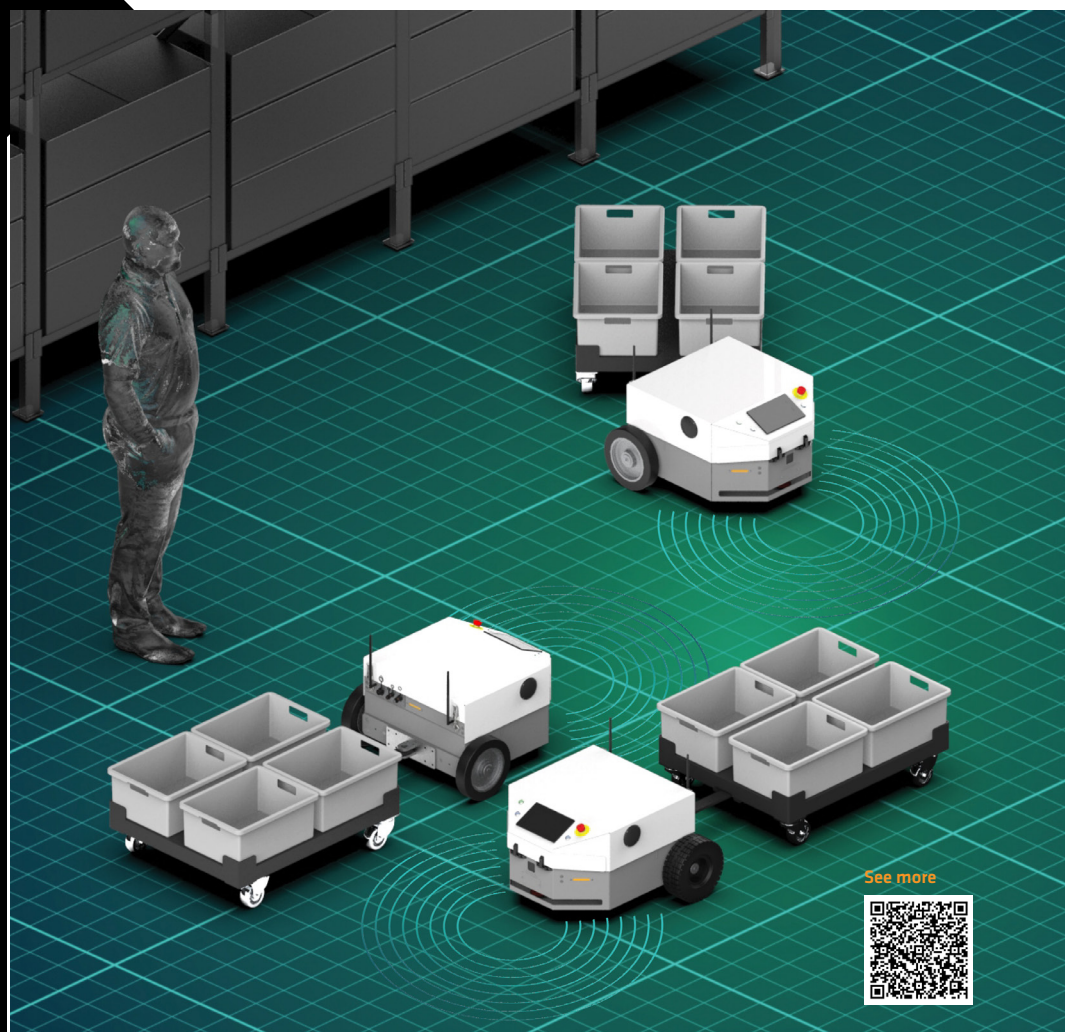

See more



Robot type	MOBOT® TRANSPORTER T15
Payload and transport method	
Way of transporting cargo	The robot is towing carts; replaceable clip on the back of the robot
Permissible total weight of the load	1500 kg
Power supply	
Automatic battery charging connector	Induction charging system for lithium-ion batteries
Robot power supply	- Standard battery pack Li-Ion 32 Ah/ 51.8 V (1657 Wh) - Optional battery pack Li-Ion 64 Ah/ 51.8 V (3314 Wh)
Charging	- Automatic charger with stationary coil: Charger dimensions: 385x309x127 mm (H x W x D) Dimensions of stationary coil: 50 x 250 x 15 mm (H x W x D) Stationary coil cable length: 3 m
Average operating time	Operating time: ~80 min* * The actual operating time of an industrial truck without an operator depends on, among other things, the number of batteries, the operating conditions of the truck, such as the load it is carrying, the speed of the truck or the ground on which it is moving, as well as the number of stops caused by intrusion into the safety zones of the laser scanner.
Battery charging time	Charging time from 10% to 100%: ~40 min
Speed and performance	
Maximal speed	5 km/h
Nominal power	3500 W
Movement directions	Forward movement, turning, rotation around drive wheel axles
Turning radius	Possibility of turning in place
Maximum surface slope	Robot designed to run on flat surfaces, ~3°
Navigation	
Navigation	- LMS laser, intelligent and autonomous navigation * - Manual robot control from a PC * LMS - laser navigation system
Communication	
Communication	2.4 GHz Wi-Fi, optional 2.4 GHz industrial radio module (RS232)
Connector	- Ethernet M12 (4 pin) - communication with PC, MODBUS TCP / IP - I/O switch: 24 VDC supply output (max. 2 A) + 2 inputs + 2 outputs (max. 0.5A) + CAN * - Optional power connector: 40...58VDC power supply output (max. 10A) + 2 power outputs (max. 10A) - Optional external safety circuit connector * option of connecting an optional I/O expansion module
Drive and control	
Drive	2 x servo motor (brushless), wheels with a diameter of 250 mm
Control and steering	- 1 x 7 "touch operator panel - 1 x emergency stop - 1 x emergency stop reset confirmation button - 1 x power switch - 1 x function button
Sensors	
Sensors	- 2D laser scanner for navigation with safety function optional line tracking vision system
Signaling	- 2 with speaker (voice / music messages) - 1 x turn signal (RGB LED strip) in the front of the robot - optional Bluespot
Environment	
Operating temperature range	-25 °C... +50 °C
Humidity range	10mm/h
Rain	3 mm/h SWE, water equivalent of snow cover
Snowfall	≥ 50 m (MOR, meteorological visibility)*
Fog	* detailed information is specified in the scanner's operating instructions
Protection degree	IP65
The intensity of external light	Halogen light ≤ 12.000 lx (IEC 61496-3) Sunlight ≤ 40.000 lx (IEC 61496-3)
Dimensions and weight	
Dimensions (L x W x H)	1029 x 818 x 479 mm
Total weight (with batteries)	~ 340 kg

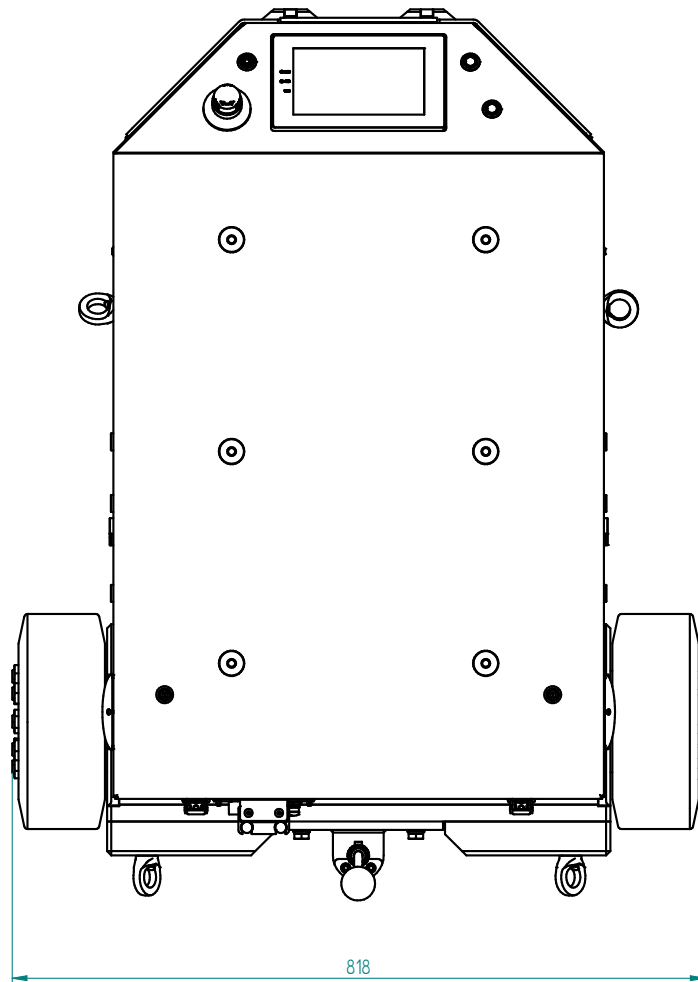
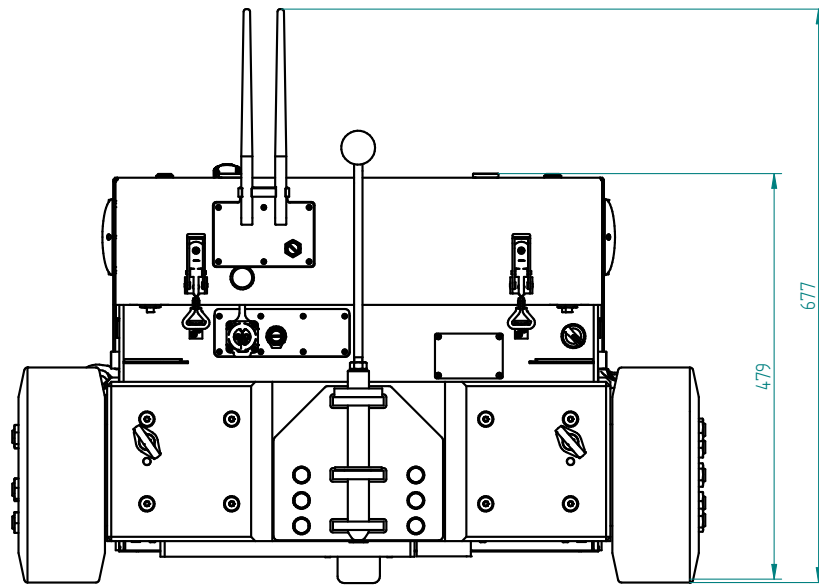

All dimensions are approximate values and can change.

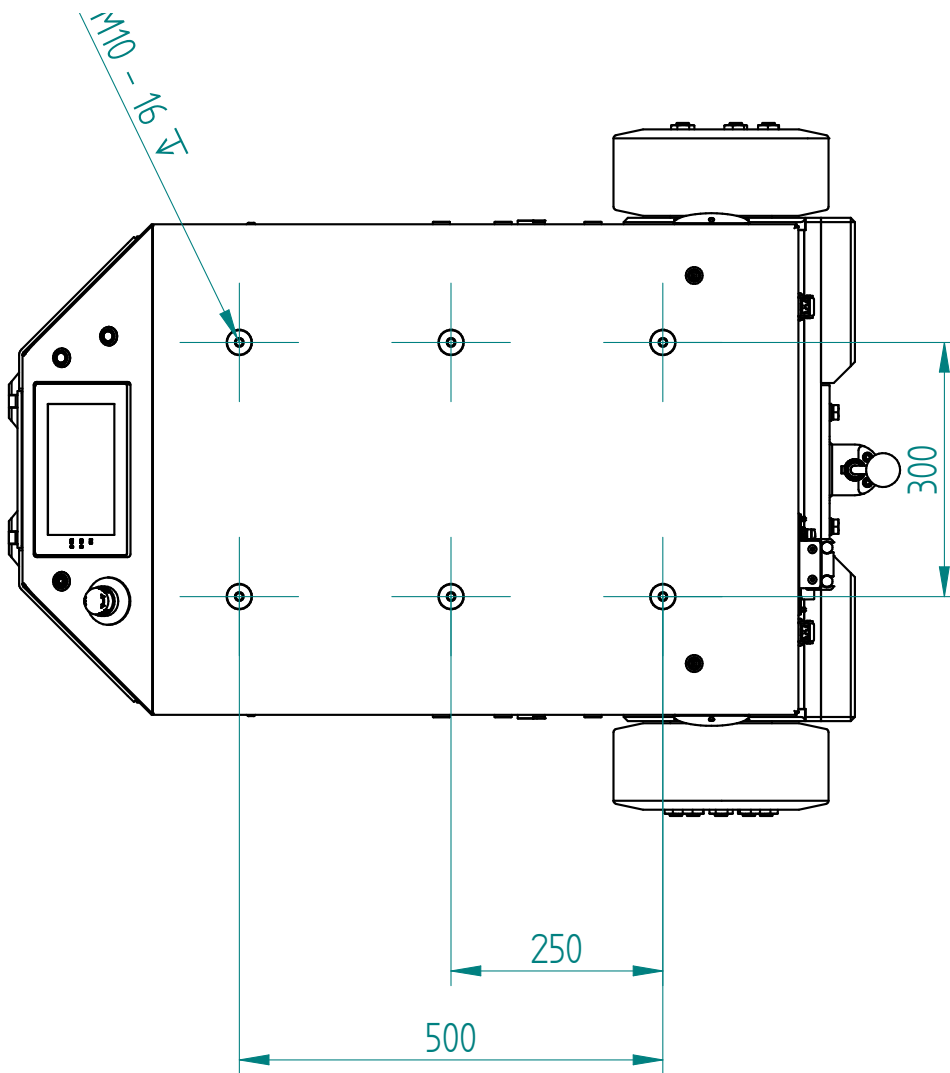
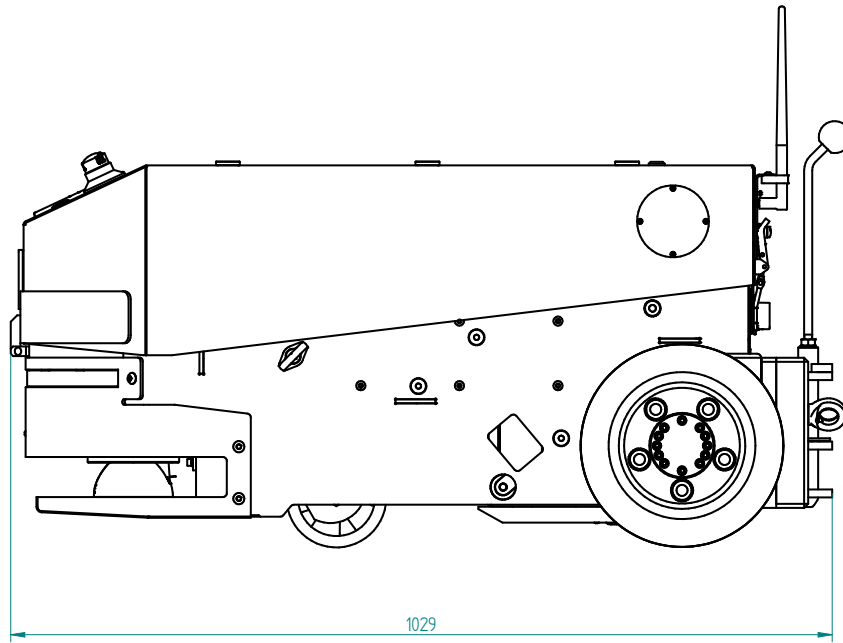

All dimensions are approximate values and can change.