

Information	Stage	Ratio	RAM060	RAM090	RAM120	RAM150	RAM180	RAM220
Defined Output Torque (Nm)	1	3	44	168	260	500	880	1390
		4	64	188	265	510	880	1390
		5	60	180	265	510	880	1390
		7	55	176	265	510	880	1390
		10	44	168	260	500	880	1390
	2	9	44	168	260	500	880	1390
		12	44	168	260	500	880	1390
		15	44	168	260	500	880	1390
		16	64	188	265	510	880	1390
		20	64	188	265	510	880	1390
		21	44	168	260	500	880	1390
		25	60	180	265	510	880	1390
		28	55	176	265	510	880	1390
		30	44	168	260	500	880	1390
		35	55	176	265	510	880	1390
		40	64	188	265	510	880	1390
		49	55	176	265	510	880	1390
		50	60	180	265	510	880	1390
	70	55	176	265	510	880	1390	
3	100	60	180	265	510	880	1390	
Peak Output Torque (Nm)	1, 2, 3	3-100	1.5 times of the Defined Output Torque					
Backlash (arc min)	1	3~10	≤8	≤8	≤8	≤8	≤8	≤8
	2	9~70	≤10	≤10	≤10	≤10	≤10	≤10
Max. Input Speed (rpm)	1	3~10	7500	5500	4500	3500	3000	2200
	2	9~70	8000	6000	6000	6000	6000	4800
Efficiency (%)	1	3~10	≥94					
	2	9~70	≥92					
Noise (dB)	1, 2, 3	3-100	76	77	77	78	79	80
Life Time (hrs)			20000					
Temperature (°C)			-15°C~+90°C					
Protection Rank			IP64					
Lubricant			Synthetic Lubricant					

Przekładnie planetarne kątowe RAM



www.wobit.com.pl

Information		Stage	Ratio	RAM060	RAM090	RAM120	RAM150	RAM180	RAM220	
Allowable Radial Force (N)		1, 2	3~70	1600	2700	3100	4800	7000	13000	
Allowable Axial Force (N)				800	1350	1550	2400	3500	6500	
Weight (kg)	RAM - H	stage 1		3.5	9.5	13.2	28.4	50.4	51.7	
		stage 2		3.8	10.5	15.2	33.4	65.4	66.7	
	RAM - S	stage 1		3.7	10.0	14.3	31.1	55.4	97.4	
		stage 2		4.0	11.0	16.4	36.4	70.4	113.4	
	RAM - 2S	stage 1		3.9	10.2	14.6	32.4	57.4	101.3	
		stage 2		4.2	11.2	16.7	36.9	72.4	117.3	
	RAM - D	stage 1		3.6	9.4	13.2	28.5	51.7	83.5	
		stage 2		3.9	10.4	15.3	33.5	66.7	99.5	
	RAM - F	stage 1		3.7	9.9	13.5	29.4	51.0	85.8	
		stage 2		4.0	10.9	15.6	34.4	66.0	101.5	
	Mass Moment of Inertia (kg X cm ²)		1	3	0.372	2.31	4.74	20.85	62.9	163.2
				4	0.229	1.44	2.98	12.83	38.9	100.3
5				0.168	1.10	2.29	9.46	28.9	73.9	
7				0.123	0.86	1.80	7.86	24.4	61.4	
10				0.093	0.71	1.49	6.69	21.0	52.5	
2			9	0.175	1.28	2.85	14.59	46.2	114.4	
			12	0.160	1.19	2.69	14.23	45.2	111.1	
			15	0.150	1.15	2.58	14.03	44.7	110.1	
			16	0.109	0.82	1.82	8.83	28.1	69.4	
			20	0.091	0.71	1.55	7.81	24.9	61.1	
			21	0.309	1.92	3.94	17.30	52.2	135.4	
			25	0.089	0.70	1.52	6.78	21.7	52.8	
			28	0.084	0.67	1.42	6.47	20.6	50.0	
			30	0.075	0.60	1.31	6.11	19.5	47.2	
			35	0.082	0.65	1.39	6.38	20.4	49.5	
			40	0.075	0.61	1.31	6.11	19.5	47.4	
			49	0.082	0.65	1.39	6.38	20.4	49.5	
			50	0.074	0.61	1.30	5.91	18.9	45.7	
			70	0.073	0.59	1.27	5.84	18.7	45.3	
			3	100	0.086	0.69	1.49	6.69	21.4	52.0

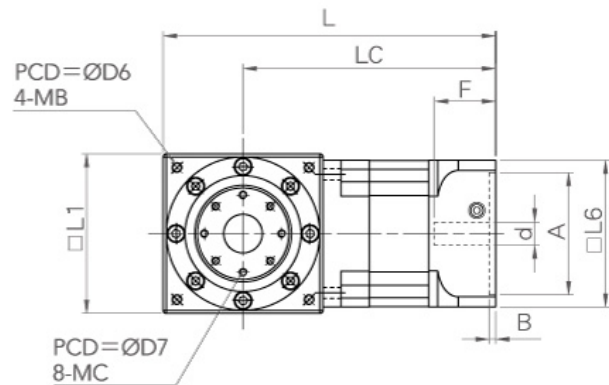
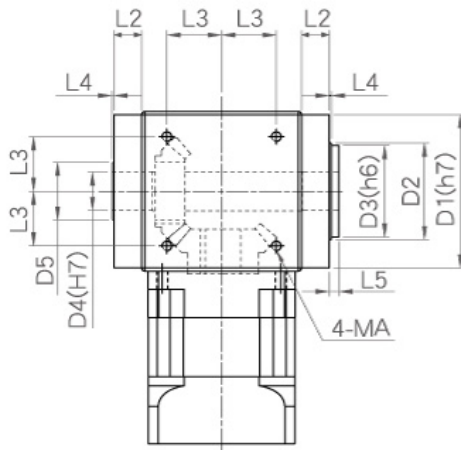

Unit: mm

Info.	RAM060-F	RAM090-F	RAM120-F	RAM150-F	RAM180-F	RAM220-F	
L 1	83	114	124	154	183	220	
L 2	17	21.5	21.5	19	20	20	
L 3	28.284	33.587	38.89	45.962	56.569	72.478	
MA	M5xP0.8x10	M6xP1.0x12	M8xP1.25x14	M10xP1.5x22	M12xP1.75x22	M16xP2.0x16	
L 4	1.5	1.5	1.5	1.5	1.5	1.5	
L 5	7.5	7.5	7.5	7.5	7.5	7.5	
L 6	60	94	114	142	180	220	
LC	Stage 1	146.2	187	196.8	282	327	340
	Stage 2	168.2	215.5	224.8	334	409.5	446.5
L	Stage 1	187.7	244	258.8	359	418.5	450
	Stage 2	209.7	272.5	286.8	411	501	556.5
D1	79	109	119	149	169	217	
D2	45	60	75	80	90	125	
D3	44	59	71	79	89	124	
D4	15	20	30	35	50	75	
D5	25	35	45	55	65	105	
D6	100	130	145	190	185	240	
MB	M5xP0.8x10	M6xP1.0x12	M8xP1.25x14	M10xP1.5x22	M12xP1.75x22	M16xP2.0x16	
D7	35	50	60	68	76	111	
MC	8-M5xP0.8x12	8-M5xP0.8x15	8-M6xP1.0x15	12-M6xP1.0x15	12-M8xP1.25x15	12-M8xP1.25x15	
d	≤14	≤24	≤28	≤42	≤55	≤65	
A	30~50	50~80	50~110	95~130	95~150	110~200	
B	6	6	5	10	11	12	
F	≤35	≤47.5	≤47.5	≤66.5	≤82.5	≤88.5	