



Operating Instructions
optoNCDT ILR1171

ILR1171-125

Laser distance measuring device
Non-contact laser-optic distance sensor

MICRO-EPSILON Eltrotec GmbH
Manfred-Wörner-Straße 101

73037 Göppingen / Germany

Tel. +49 (0) 7161 / 98872-300
Fax +49 (0) 7161 / 98872-303
e-mail eltrotec@micro-epsilon.com
www.micro-epsilon.com

Contents

1.	Safety	5
1.1	Symbols Used	5
1.2	Warnings	5
1.3	Notes on CE Marking	6
1.4	Intended Use	6
1.5	Proper Environment.....	6
2.	Laser Safety	7
3.	Functional Principle, Technical Data	8
3.1	Short Description	8
3.2	Operating Elements	8
3.3	Technical Data	9
4.	Delivery	10
4.1	Unpacking/Included in Delivery	10
4.2	Storage	10
5.	Installation and Assembly	11
5.1	Notes for Operation	11
5.1.1	Laser Beam Image	11
5.1.2	Interferences.....	12
5.1.2.1	Thermal Influences	12
5.1.2.2	Mechanical Vibrations	12
5.1.2.3	Motion Blur	12
5.1.2.4	Angular Influences	12
5.2	Sensor Mounting	13
5.3	Electrical Connections.....	14
5.3.1	Connection Options	14
5.3.2	Pin Assignment.....	15
5.3.3	Supply Voltage	16
5.3.4	Analog Output	16
5.3.5	Switching Outputs	17
5.3.6	Trigger Input / Output	18
5.3.7	Serial Interface RS232 / RS422	20
5.3.8	RS422 Connection with USB Converter IF2001/USB	21
6.	Operation	22
6.1	Generally.....	22
6.2	Measurement Involving Moving Targets.....	22
7.	Serial Interface RS232 and RS422	23
7.1	Properties.....	23
7.2	Data Decoding Binary Format	23
8.	Using the ILR1171 via the Serial Interface with a Terminal Program	24
8.1	Retrieving Parameters	24
8.2	Setting Parameters	24
8.3	Start Distance Measurement (Operation Mode)	24
9.	Cleaning	25
10.	Software Support with MEDAQLib	26
11.	Disclaimer	27
12.	Service, Repair	27
13.	Decommissioning, Disposal	27

Appendix

A 1	Optional Accessories	28
A 2	Factory Settings	28
A 3	ASCII Communication with Sensor	29
A 3.1	General Information	29
A 3.2	Commands Overview	30
A 3.3	Identification.....	31
A 3.3.1	ID Recognition	31
A 3.3.2	ID? - Online Help	31
A 3.4	Operation Modes	31
A 3.4.1	DM - Single Distance Measurement.....	32
A 3.4.2	DT - Continuous Distance Measurement (Distance Tracking)	32
A 3.5	Status	32
A 3.5.1	TP - Internal Temperature	32
A 3.5.2	HW - Hardware Status	33
A 3.5.3	PA - Display Parameter Setting	33
A 3.5.4	PR - Parameter Reset	34
A 3.6	Setup Parameters	34
A 3.6.1	AS - Autostart Function	34
A 3.6.2	BR - Baud Rate	35
A 3.6.3	DR - ILR1171 Restart (Device Reset)	35
A 3.6.4	GN - Setup GAIN	35
A 3.6.5	MF - Measurement Frequency	36
A 3.6.6	MW - Measurement Window	37
A 3.6.7	OF - Offset	37
A 3.6.8	QA - Analog Output	38
A 3.6.9	Q1/Q2 - Switching Output	39
A 3.6.10	SA - Mean Value Average.....	39
A 3.6.11	SO - Set Offset.....	40
A 3.6.12	SD - Data Format of Serial Interface Output	40
A 3.6.13	SE - Error Mode.....	41
A 3.6.14	ST - Select Target	41
A 3.6.15	TC - Time Calibration.....	41
A 3.6.16	TE - Terminator	42
A 3.6.17	TI + TO Trigger.....	42
A 3.6.17.1	TI - Trigger Input.....	43
A 3.6.17.2	TO - Trigger Output.....	43
A 3.6.17.3	AUTOTRIGGER Function - Continuous Distance Tracking Controlled by Trigger ..	44
A 3.6.18	UB - Unit for Binary Output.....	44
A 3.7	ASCII Error Messages	45

1. Safety

System operation assumes knowledge of the operating instructions.

1.1 Symbols Used

The following symbols are used in these operating instructions:



Indicates a hazardous situation which, if not avoided, may result in minor or moderate injury.



Indicates a situation that may result in property damage if not avoided.



Indicates a user action.



Indicates a tip for users.

Measurement

Indicates hardware or a software button/menu.

1.2 Warnings



Connect the power supply according to the safety regulations for electrical equipment.

- > Risk of injury
- > Damage to or destruction of the sensor



Refrain from using the sensor in an explosive environment.

- > Damage to or destruction of the sensor and/or other proximate equipment

Cable connectors must not be plugged or unplugged, as long as voltage is supplied. Remember to turn voltage supply off before you begin working on cable connections.

- > Damage to or destruction of the sensor

The supply voltage must not exceed the specified limits.

- > Damage to or destruction of the sensor

Avoid shocks and impacts to the sensor.

- > Damage to or destruction of the sensor

Protect the cables against damage.

- > Failure of the measuring device

Do not turn the module on if there is fogging or soiling on its optical parts.

- > Failure of the measuring device

Do not touch any of the module's optical parts with bare hands. Proceed with care when removing dust or contamination from optical surfaces.

- > Failure of the measuring device

Avoid measurements against the sun or onto surfaces with low reflectivity in very bright environments.

- > Incorrect measurement

Avoid measurements through glass, optical filters, Plexiglas or other translucent materials.

- > Incorrect measurement

i Information and warning signs must not be removed.

1.3 Notes on CE Marking

The following apply to the optoNCDT ILR1171:

- EU Directive 2014/30/EU
- EU Directive 2011/65/EU

Products which carry the CE mark satisfy the requirements of the EU directives cited and the relevant applicable harmonized European standards (EN). The measuring system is designed for use in industrial and laboratory applications.

The EU Declaration of Conformity and the technical documentation are available to the responsible authorities according to the EU Directives.

1.4 Intended Use

The optoNCDT ILR1171 is designed for use in industrial and laboratory applications (research and development facilities). It is used for

- Process monitoring in steel-Works and rolling mills
- Fill-level measurement
- Monitoring of moving objects
- Positioning of cranes and loading equipment
- Position monitoring of road vehicles and ships
- Speed measurement of vehicles and ships
- The system must only be operated within the limits specified in the technical data, [see 3.3](#).
- The system must be used in such a way that no persons are endangered or machines and other material goods are damaged in the event of malfunction or total failure of the system.
- Take additional precautions for safety and damage prevention in case of safety-related applications.

1.5 Proper Environment

- Protection class: IP67
- Temperature range:
 - Operation: -40 ... +60 °C (-40 ... +140 °F) ¹
 - Storage: -40 ... +70 °C (-40 ... +158 °F)
- Humidity: 15 ... 90 % RH (non-condensing)
- Ambient pressure: Atmospheric pressure

1) The heating element ensures the temperature range of operation of the components and free optics (no condensation) of the optoNCDT ILR1171.

2. Laser Safety

The optoNCDT ILR1171 works with a semi-conductor laser at a wavelength of 905 nm (invisible/infrared). The maximum optical power is ≤ 1 mW.

The sensors fall within laser class 1.

The accessible radiation is harmless under predictable conditions. For class 1 laser devices, impairment of color vision and disturbances, e.g., from a glare effect, cannot be excluded.

Consequently, you can use Class 1 laser equipment without further protective measures.

Lasers of Class 1 are not subject to notification and a laser protection officer is not required.

The following warning labels must be attached to the cover (front side) of the sensor housing. The IEC laser warning labels have already been attached. For other non German speaking countries, an IEC standard label and a German label are included in delivery and the versions valid for the user`s country must be attached before the device is put into operation for the first time.

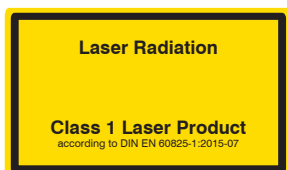

Fig. 1 Laser label



Fig. 2 Sensor with laser labels

The housing of the optical sensors may only be operated by the manufacturer, [see 11](#).

For repair and service purposes, the sensors must always be sent to the manufacturer.

3. Functional Principle, Technical Data

3.1 Short Description

The optoNCDT ILR1171 is a laser-based distance sensor for non-contact and precise distance and displacement measurements from 0.2 m up to 270 m. The sensor is designed for very large measuring ranges, with and without reflector. Due to the very high measuring rate of the sensor, moving objects can be measured easily. The sensor operates according to the laser pulse runtime principle and is therefore particularly well suited to applications with large distances. Commissioning of the sensor is straightforward due to a variety of interfaces and easy mounting options. The optoNCDT ILR1171 is fitted with an integrated heater for outdoor use. A pilot laser is also integrated for mounting and adjustment.

The sensor measures distances to moving and static targets:

- with measuring range from 0.2 m up to 125 m on diffuse reflective surfaces with 90 % reflectivity,
- with measuring range from 0.2 m up to 270 m on reflector surfaces, for example Scotchlite series 3290,

The actual range of measurement depends on the reflectivity and the surface quality of a target being measured. The sensor is available with RS232 or RS422.

The sensor contains two switching outputs and one external trigger input and trigger output (all of them parameterizable).

A distance measurement can be triggered:

- via RS232 interface or RS422 interface
- by an external source (in external trigger mode).

3.2 Operating Elements



- 1 n.c.
- 2 Measurement control LED, multicolor
- 3 12-pin M12-A female connector, type Binder

Fig. 3 Operating elements of the sensor optoNCDT ILR1171

The optoNCDT ILR1171 has a measurement control LED. The LED is flashing green during measuring without a failure. The LED is flashing red if a failure is happened.

3.3 Technical Data

Model		ILR1171
Item number		7112027
Measuring range ¹	Black 10 %	70 m
	Gray 40 %	100 m
	White 80 %	125 m
	Reflector film ²	270 m
Start of measuring range		0.2 m ³
Measuring rate		40 kHz
Resolution		1 mm
Linearity		< ±60 mm ⁴
Repeatability ⁵		< 25 mm
Temperature stability		≤ 20 ppm / K
Light source		Semiconductor laser < 1 mW, 905 nm (red)
Laser class		Class 1 according to DIN EN 60825-1:2014
Permissible ambient light		50,000 lx
Supply voltage		10 ... 30 VDC
Power consumption		< 3 W (24 V)
Signal input		Trigger
Digital interface		RS232 / RS422
Analog output		4 ... 20 mA (16 bit, freely scalable within the measuring range)
Switching output		Q1 / Q2 (configurable); trigger
Connector		Supply/signal: 12 pin M12 screw/plug connection
Mounting		Mounting holes
Temperature range	Storage	-40 ... +70 °C (non-condensing)
	Operation	-20 ... +60 °C (non-condensing)
Shock (DIN EN 60068-2-29)		30 g / 6 ms in 6 directions, 3 shocks each
Vibration (DIN EN 60068-2-6)		1 g / 10 ... 2000 Hz in 3 axes, 2 cycles each
Protection class (DIN EN 60529)		IP67
Material		Aluminum housing
Weight		approx. 140 g
Control and indicator elements		2x LEDs for power and signal
Special features		Measurement-specific operating modes

SMR = Start of measuring range, EMR = End of measuring range

1) Depends on the reflectivity of the target, ambient light interference and atmospheric conditions

2) ILR-RF250 reflector film 250 x 250 mm; art. 7966001

3) 0.5 m measuring with reflector film

4) Linearity in the range ≤ 1 m and in the range ≥ 70 m is ±100 mm.

5) Repeatability in the ranges ≤ 1 m and ≥ 70 m is ±50 mm.

4. Delivery

4.1 Unpacking/Included in Delivery

1 Sensor ILR1171-125

1 Assembly instructions

1 German laser label

1 IEC laser label

► Carefully remove the components of the measuring system from the packaging and ensure that the goods are forwarded in such a way that no damage can occur.

► Check the delivery for completeness and shipping damage immediately after unpacking.

► If there is damage or parts are missing, immediately contact the manufacturer or supplier.

Optional accessories are available in the appendix, [see A 1](#).

4.2 Storage

Temperature range for storage: -40 ... +70 °C (-40 ... +158 °F)

Humidity: 15 ... 90 % RH (non-condensing)

5. Installation and Assembly

5.1 Notes for Operation

5.1.1 Laser Beam Image

- Divergence of laser
 - Transmitter: 2 mrad x 0.4 mrad
 - Receiver: 5.8 mrad

The optoNCDT ILR1171 works with a measuring laser (invisible/infrared).

The table below shows the size of the laser spot on the target in dependence on the distance.

- Installation of optoNCDT ILR1171

The lenses of optoNCDT ILR1171 are vertical about each other.



Fig. 4 View of the 2 lenses (transmitter and receiver)

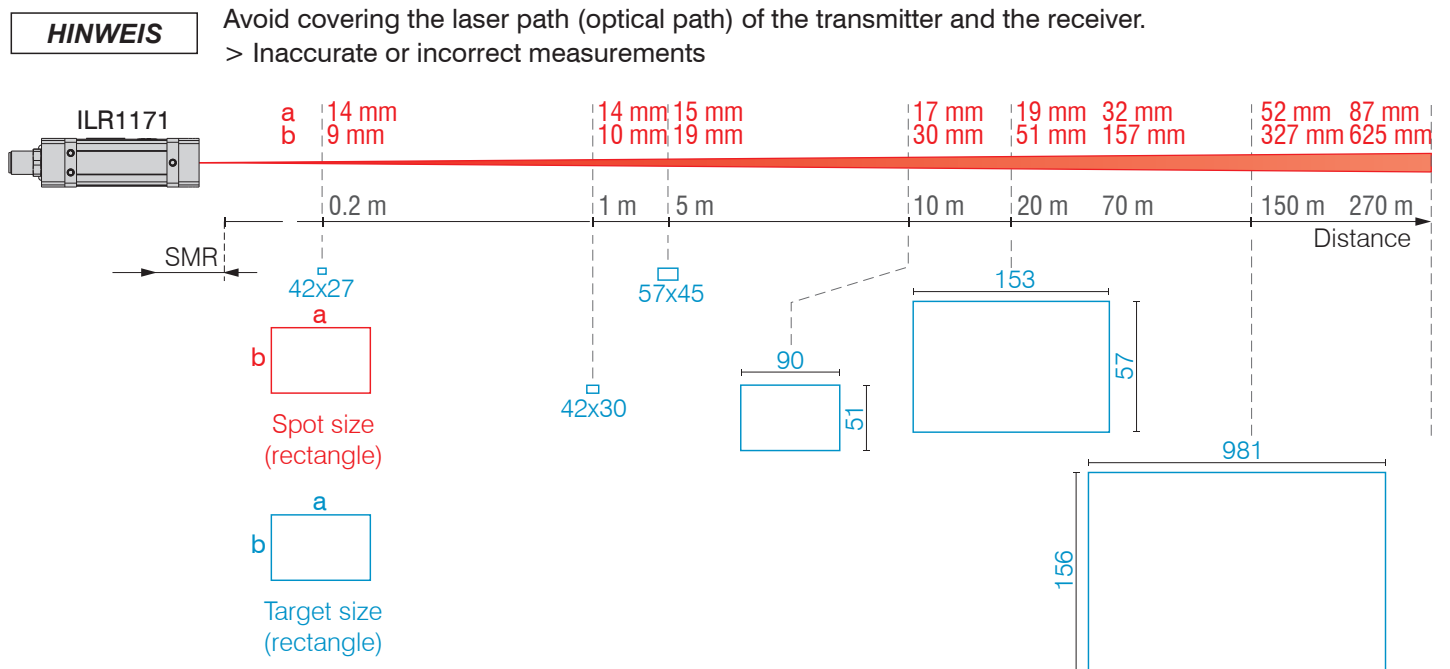

Fig. 5 Laser spot dimensions and size of measuring object depending on the distance

The above-mentioned laser spot holds approx. 50 % of the entire laser energy. An aura with less energy forms around that spot.

5.1.2 Interferences

5.1.2.1 Thermal Influences

When the sensor is commissioned, a warm-up time of at least 5 minutes is required to achieve uniform temperature distribution in the sensor.

Rapid temperature changes are not detected immediately due to the damping effect of the sensor's heat capacity.

5.1.2.2 Mechanical Vibrations

If a high degree of accuracy or a long range is required, the sensor and target must be mounted on a stable surface that is damped against vibrations.

5.1.2.3 Motion Blur

A constant travel movement of up to 25 m/s is possible in all cases. Targets that move faster or that are not very reflective can cause motion blurring.

5.1.2.4 Angular Influences

We recommend an angle of 90° for the laser to strike the target. Tilt angles might impair the measurement accuracy.

In principle, angular behavior during laser distance measurement is also affected by the reflective properties of the target surface.

5.2 Sensor Mounting

The sensor optoNCDT ILR1171 is an optical sensor for measurements with millimeter accuracy.

- i** Ensure careful handling during installation and operation.

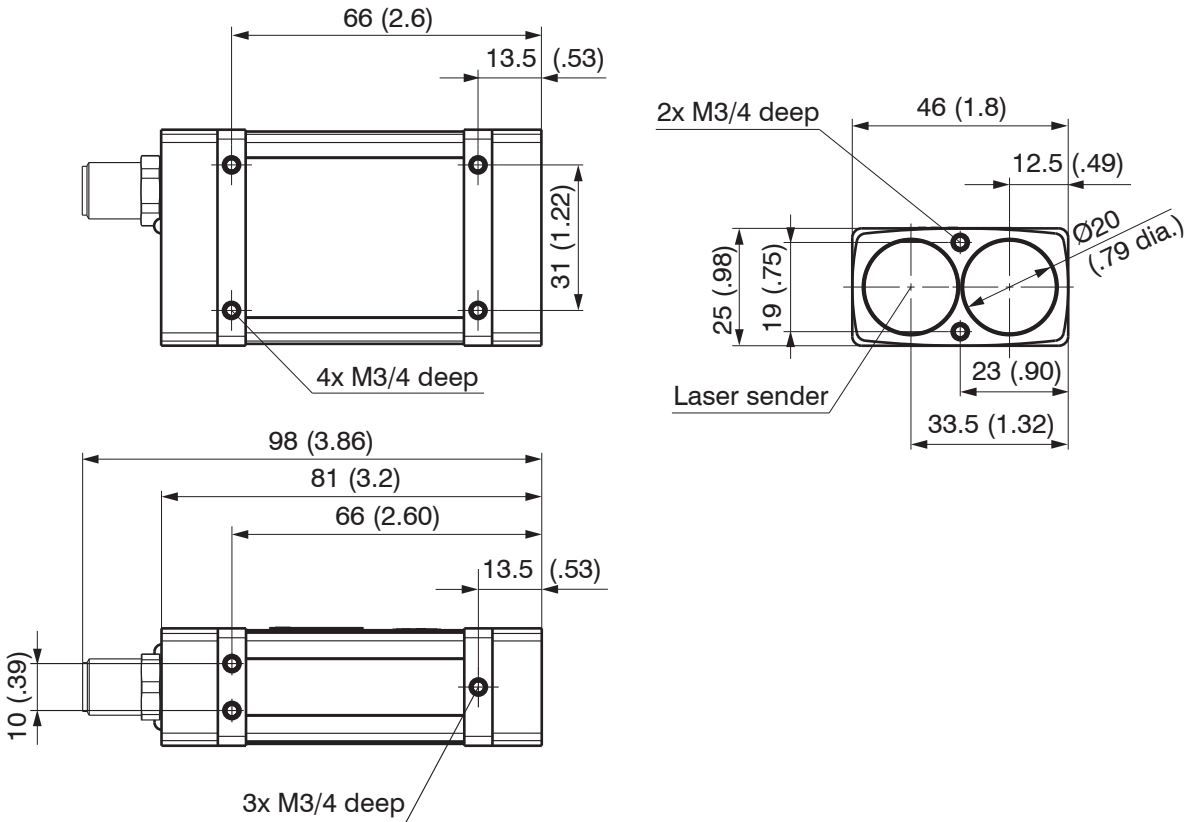

Fig. 5 Dimensional drawing optoNCDT ILR1171, dimensions in mm (inches)

The optoNCDT ILR1171 can be screwed on 3 positions:

- front with 2 screws M3
- bottom side with 4 screws M3
- one small side with 3 screws M3

- i** Mount the sensor only to the existing through-bores on a flat surface. Any type of clamping is not permitted. Never exceed the specified torques. Choose the length depending on the counter piece.

Bolt connection ¹					
Position	Bolt length	Screwing depth	Quantity	Screw	Torque
Front side	10 mm	4 mm	2	M3 ISO 4762-A2	1.7 Nm for strength class 70 2.3 Nm for strength class 80
Bottom side	10 mm	4 mm	4		
One small side	10 mm	4 mm	3		

Fig. 6 Installation conditions

MICRO-EPSILON recommends using the screws with washer and ring washer.

The zero point for measurement is identical with the housing front face.

1) Recommendation: Test under use conditions!

5.3 Electrical Connections

5.3.1 Connection Options

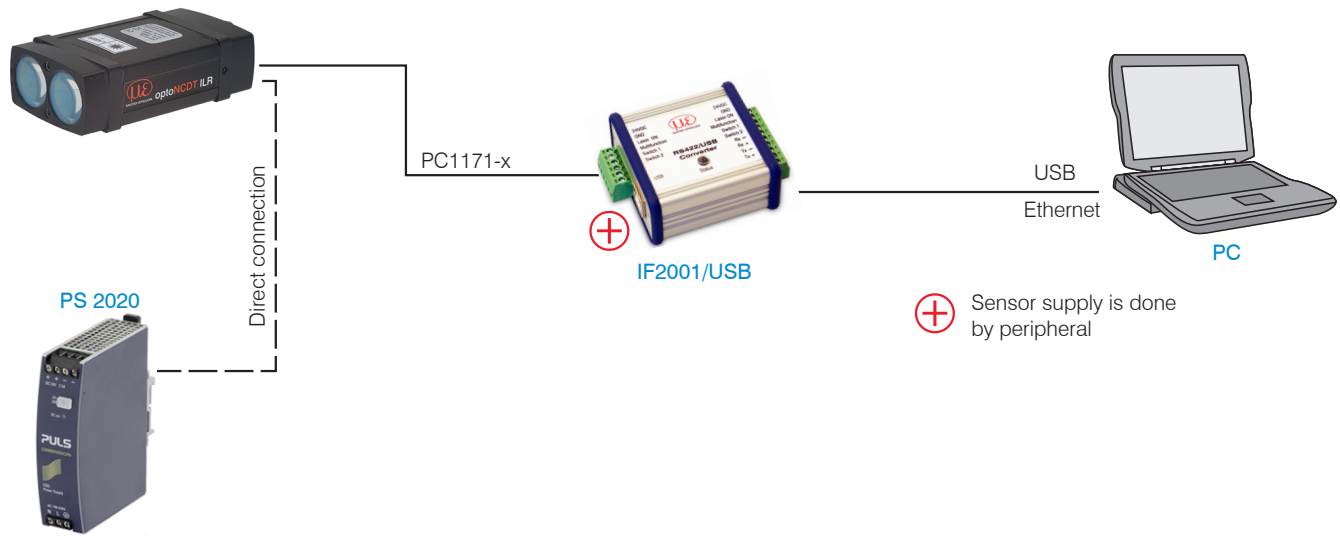
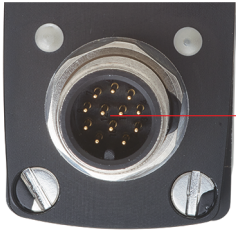

Fig. 7 Connection examples on ILR1171

5.3.2 Pin Assignment

Depending on the implemented configuration version of the various sensor models, different terminal facilities are available for connections. All models share the same type of main connector port/interface, see Fig. 8.



Supply voltage/RS232/422 12-pin M12-A female connector, type Binder

Fig. 8 Connector on the rear side of the sensor

The connector is located on the rear side of the sensor.

The assignment of the power supply/serial interface results from a 12-pole round-type (flange mount) series 723 connector from Binder.

This connector type guarantees optimized screening and a high IP degree. The required counterpart is an adequate female cable connector with grading ring.

MICRO-EPSILON recommends the optionally available supply and output cable PC1171-x, see A 1.

Bending radius of the supply and output cable PC1171-x:

- 47 mm (once)
- 116 mm (permanent)

Pin	Signal	Description	Wire color PC1171-x	 <p>View on solder pin side, M12-A female connector, type Binder</p>
1	Q1	Switching output Q1	Brown	
2	VDC-	GND (supply voltage)	Blue	
3	RS422 / RS232	Pin for RS422 or RS232	White	
4	TX+	RS422 transmission data + RS232 transmission data	Green	
5	RX-	RS422 receiving data -	Pink	
6	TX-	RS422 transmission data -	Yellow	
7	Q2	Switching output Q2	Black	
8	RX+	RS422 receiving data + RS232 receiving data	Gray	
9	VDC+	Supply voltage 10 ... 30 VDC	Red	
10	TRIGIO	Trigger signal IN / OUT	Violet	
11	QA	Analog output	Gray/pink	
12	GND	GND (Qx, RS232, RS422, trigger)	Red/blue	

Fig. 9 Pin Assignment optoNCDT ILR1171

Inverse polarity protection is provided.

Overvoltage protection is provided up to a maximum of 42 V DC.

- The shield of the cable should be connected to the connector housing.
- Open, unused cable wires must be insulated.

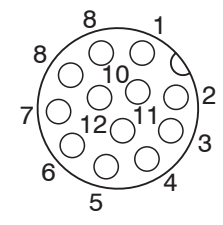
5.3.3 Supply Voltage

Nominal value 24 VDC (10 ... 30 V)

- Only turn on the power supply after wiring has been completed.
- Connect the 2 (blue) and 9 (red) inputs on the sensor to a 24 V voltage supply.

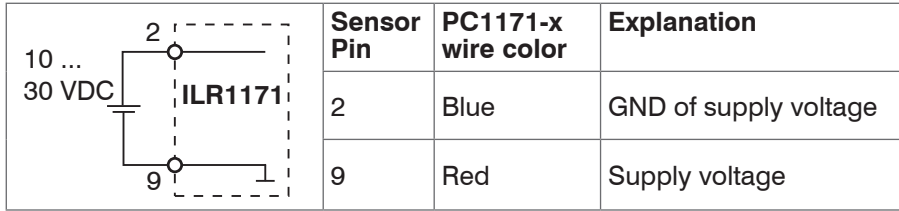

Fig. 10 Supply voltage connection

Voltage supply only for measuring devices, not to be used for drives or similar sources of impulse interference at the same time.

MICRO-EPSILON recommends using the optionally available PS2020 power supply, see A 1, for the sensor.

5.3.4 Analog Output

The sensor produces a current output of 4 ... 20 mA.

- The output may not be used continuously in short-circuit operation without a load resistor.
- i Continuous short-circuit operation leads to thermal overloading and thus causes the output to switch off automatically.

- Connect the 11 (gray/pink) and 12 (red/blue) inputs on the sensor to a measuring device.

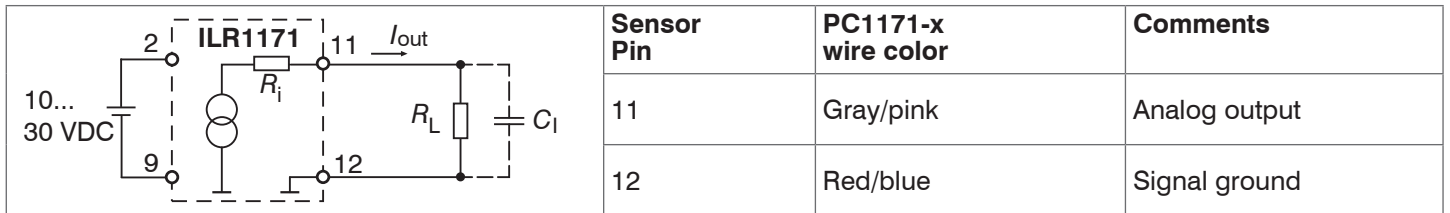

Fig. 11 Analog output switching

Analog Output Properties		
- 4 ... 20 mA	- Behavior when error reported: 3 mA	Load $R_L < V_+ - 1 \text{ V} / 20 \text{ mA}$ @10 V: $R_L < 450 \text{ Ohm}$ @24 V: $R_L < 1150 \text{ Ohm}$ @30 V: $R_L < 1450 \text{ Ohm}$
- R_i 30 Ohm	- Accuracy: 0.1 % FSO	
- Distance range limits adjustable	- Resistant to short circuits	
- Resolution: 16 bit DA converter		

The current impressed in the line is proportional to the measured distance. You can find more details on this in the Analog Output section see A 3.8.8.

- i The measured values are always output via the analog output.

5.3.5 Switching Outputs

Switching outputs Q1 and Q2 show the distance information as logical switching information. They signalize whether the preset hysteresis switching range is exceeded or fallen short of.

Thus, they are ideally suitable for direct further processing of monitored values such as fill level or object detection. Parameterization is done via the serial interface, see A 3.6.9.

A load resistor of > 150 Ohms/ 6 W (max. operating voltage of 30 V; max. load current of 0.2 A) must be switched against VDC- (GND of supply voltage) at the switching output. It is important that the load current of 0.2 A is not exceeded.

i Typical resistance: 1 kOhm against VDC (not against GND)

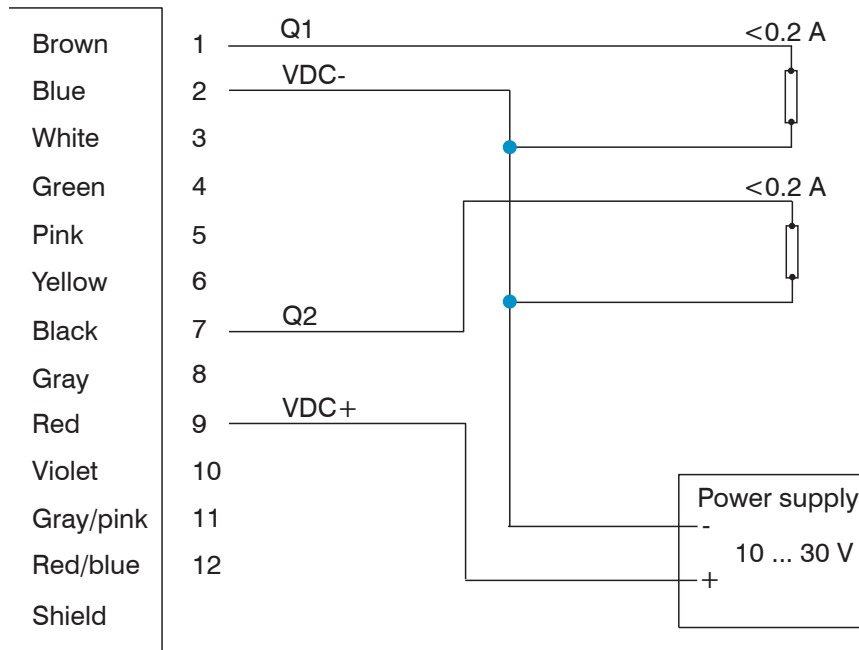
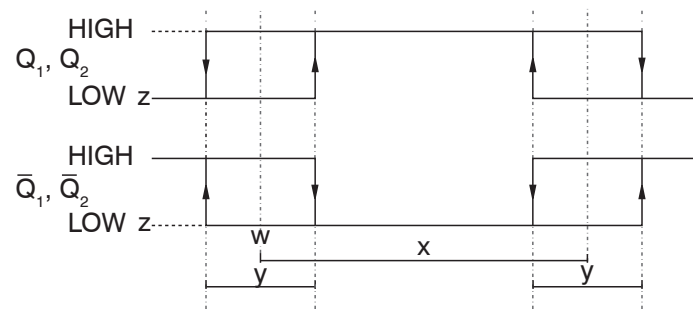

Fig. 12 Pin assignment and wiring of switching outputs Q1 and Q2

Q1/Q2, see A 3.6.9 parameterizes the behavior of the switching outputs.

The parameters include the beginning w of the measuring range (switching threshold) when the output switches, the length x of the switching range, the switching hysteresis y as well as the logic behavior z (switching state).



Low = 0 $U < 1\text{ V}$
 High = 1 $U = \text{Operating voltage} - 1\text{ V}$

Fig. 13 Switching behavior of Q1 or Q2 respectively

Variable	Description	Specification
w	Switching threshold	-9999,999 ... +9999,999
x	Switching range	$x > 0$; $x > y$
y	Switching hysteresis	$y \geq 0$
z	Switching state	$z = 0$ or 1

5.3.6 Trigger Input / Output

The optoNCDT ILR1171 trigger could be used as input or output.

- Trigger input / external trigger function:
External trigger signal will be sent. The measurement (parameter DM , see A 3.4.1) starts in accordance with parameter TI , see A 3.6.17.1.
- Trigger output / e.g. connection between 2 sensors:
The output trigger signal of the 1. LUMOS (parameterized with TO , see A 3.6.17.2) starts a single measurement DM of the second LUMOS (parameterized with TO).
- Continuous distance tracking controlled by trigger.

Voltage levels for the trigger signals

Low level	0 - 1.5 V
High level	3 - 30 V
Threshold	2.25 V
Hysteresis	0.1 V

Configure the desired trigger behavior using ASCII commands (TI , see A 3.6.17.1 and TO , see A 3.6.17.2)

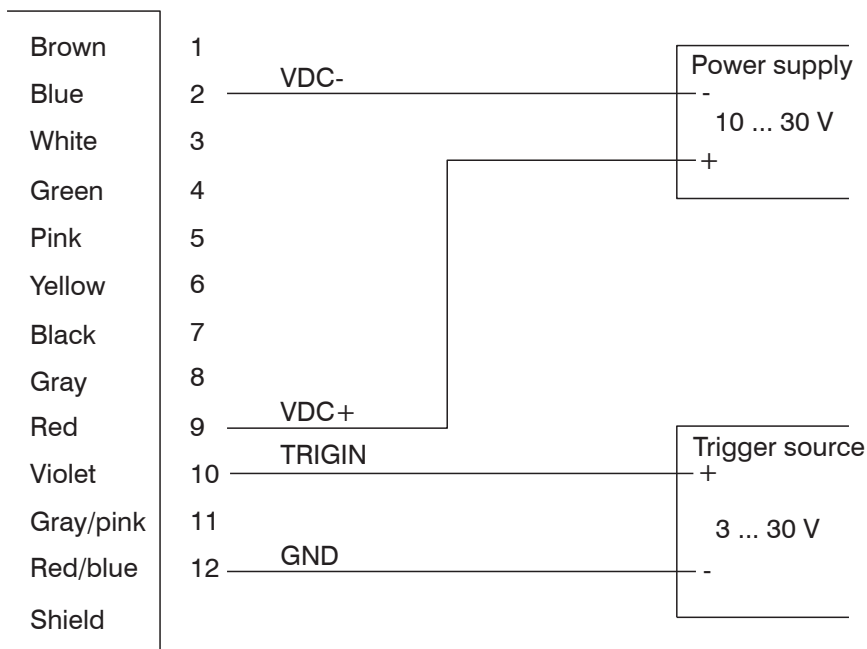

Fig. 14 Wiring of trigger input

i Maximum frequency of external trigger signal for Trigger IN: 30 kHz

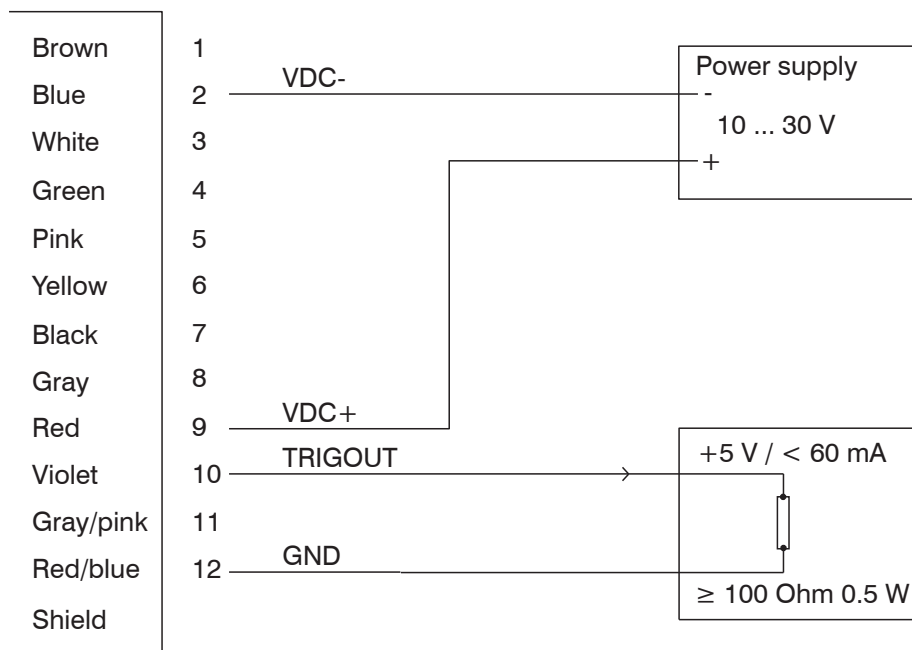

Fig. 15 Wiring of trigger output

i Maximum frequency of Trigger OUT (T_O) = MF (Measurement frequency), see A 3.6.5.

If the trigger frequency is too high, no measurement value can be determined. The output is D02, see A 3.7. The trigger frequency must be reduced.

5.3.7 Serial Interface RS232 / RS422

▶ Check the connection of Pin 3 (white) before using the serial interface RS232 or RS422.

i RS232 Pin 3 not connected.

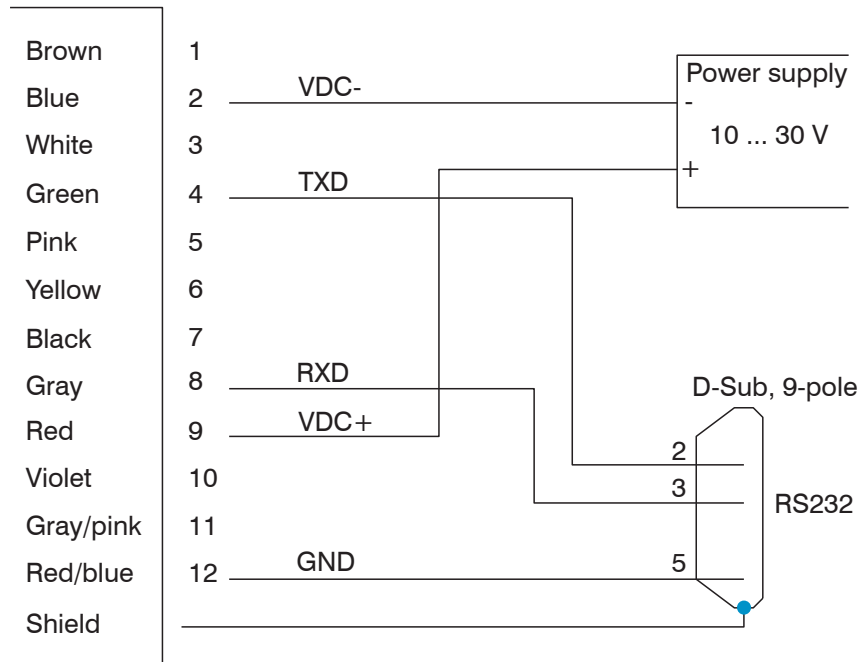

Fig. 16 Pin assignment and wiring Serial interface RS232

i RS422 Pin 3 connected with Pin 12 (GND)

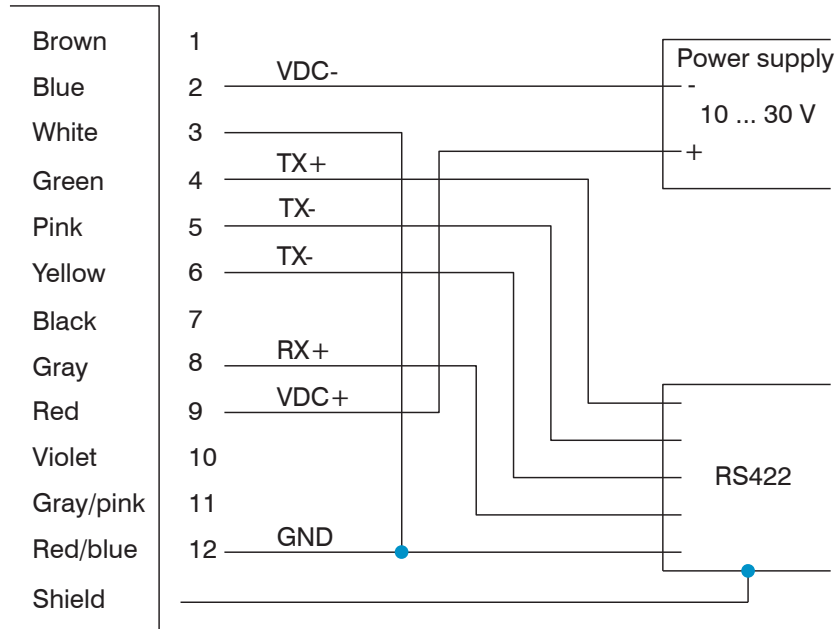

Fig. 17 Pin assignment and wiring Serial interface RS422

5.3.8 RS422 Connection with USB Converter IF2001/USB

The RS422 interface can be used for configuration as well as for permanent data transmission, even over longer distances. It is interference-resistant and suitable for industrial applications. Distances of up to 1200 m are possible with a twisted-pair cable.

For the connection between sensor and PC, the lines must be crossed.

i Only disconnect or connect the sub-D connection between the RS422 and USB converter IF2001/USB when no voltage is flowing.

Characteristics

- Maximum input voltage RX+, RX- : $\pm 14 V_{\max}$ internally terminated with 120 Ohm
- Output voltage TX: $\pm 2 V$, differential at $2 \times 50 \text{ Ohm}$

Parameter

- Baud rate 115200 baud
- Data bits: 8
- Parity: None
- Start/stop bit: 1
- Handshake: No
- Command protocol: ASCII

i The RS422 interface is widely used in industrial applications. Use a suitable USB converter, e.g. the IF2001/USB, see [Chap. A 1](#), if your PC/Notebook only has USB ports.

Sensor			Terminal, PLC, IF2001/USB Converter from MICRO-EPSILON
Pin	Wire color PC1171-x	Function	Function
8	Gray	Rx+	Tx+
5	Pink	Rx-	Tx-
6	Yellow	Tx-	Rx-
4	Green	Tx+	Rx+
12	Red/ blue	GND	GND

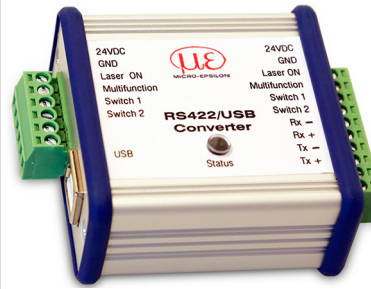

Fig. 18 Crossed data lines on receive and transmit side

Symmetrical differential signals according to EIA-422, not electrically separated from the voltage supply. Use a shielded cable with twisted wires, e. g. PC1171-x, available as an optional accessory, [see A 1](#).

6. Operation

6.1 Generally

- Insert connector in main connection port and interface.
- Protect all cable ends, which you don't use, before you turn on the power supply. So you avoid short circuits.

The user is required to implement the application-specific wiring.

- Turn-on the voltage supply for the sensor. The Power LED must light green.
- Make sensor parameter settings via RS232/RS422, [see 7](#).
- Start the distance measurement.
- Install the sensor as part of preparative actions in the designated working site, oriented onto the target and keep it in a stable position. The target to be measured should preferentially have a homogeneous, white surface.
- Lock the sensor, [see 5.2](#).

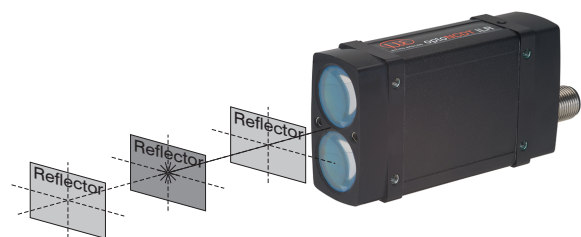

Fig. 19 Measurement against a reflector

6.2 Measurement Involving Moving Targets

Where measurements involve a moving object or the optoNCDT ILR1171 is moved during measuring, this will have an impact on the accuracy of the measured value.

This must be observed particularly when calculating average values (parameter SA , [see A 3.6.10](#)).

7. Serial Interface RS232 and RS422

7.1 Properties

- Interface settings: Asynchronous, 8 data bits, no parity, 1 stop bit
- Communication protocol format/syntax: 7-bit ASCII, [see A 3](#).
 - Standard baud rate: 115200
 - Umschalten RS422/RS232 über Verkabelung, [see 5.3.7](#)
- Decimal separator in the output of figures is the dot "." (0x2E)

7.2 Data Decoding Binary Format

Distance

2 bytes, MSB = bit 7
 MSB of byte 1 is always 1.
 MSB of byte 0 is always 0.
 Data in each byte = bit 6 ... bit 0

Coding: Two's complement
 Conversion of binary value into decimal value: *1/100

Signal

1 byte
 MSB = bit 7
 MSB of byte 0 is always 0.
 Data = bit 6 ... bit 0

Temperature

1 byte
 MSB = bit 7
 MSB of byte 1 and 0 is always 0.
 Data in each byte = bit 6 ... bit 0
 Conversion of binary value into decimal value: -40

	Distance (2 bytes)								Signal (1 byte)								Temperature (1 byte)															
	Byte 1				Byte 0				Byte 0								Byte 0															
Bit	7	6	5	4	3	2	1	0	7	6	5	4	3	2	1	0	7	6	5	4	3	2	1	0	7	6	5	4	3	2	1	0
Data	1	x	x	x	x	x	x	x	0	x	x	x	x	x	x	x	0	x	x	x	x	x	x	x	0	x	x	x	x	x	x	x

Distance	1	0	0	0	0	0	0	1	0	0	1	0	1	0	0	1	0	:100=3.38 m
----------	---	---	---	---	---	---	---	---	---	---	---	---	---	---	---	---	---	-------------

Signal	0	0	0	0	1	0	1	1	*2 = 22
--------	---	---	---	---	---	---	---	---	---------

Temperature	0	1	0	1	1	1	0	1	-40 = 53 °C
-------------	---	---	---	---	---	---	---	---	-------------

• The binary distance range will determined by parameter UB , [see A 3.6.18](#).
 ! If the distance value is below or above the distance range, the binary output is 0!

8. Using the ILR1171 via the Serial Interface with a Terminal Program

The optoNCDT ILR1171 is parameterized via a serial interface.

Prerequisite for programming via UART is a connection provided by a terminal program (e.g. Bra@s Terminal, Tera Term, Putty).

The set parameters are stored in an EEPROM.

When restarting, the last entered data will be available.

Basic settings for communication:

Baud rate: 115200
Parity: none
Data bits: 8
Stop bits: 1

➤ Select the appropriate COM port where the sensor is connected to the PC.

8.1 Retrieving Parameters

➤ Type `PARAMETER <CR>`

8.2 Setting Parameters

➤ Type `PARAMETER VALUE <CR>`

For further documentation about possible parameter and their values please consult operating instructions.

`<CR>` = 0x0d

8.3 Start Distance Measurement (Operation Mode)

➤ Type `DT <CR>`

Abort distance measurement and enable command input (setup mode)

➤ Type `<ESC>` key (=0x1b).

You will find the ASCII parameters, [see A 3](#).

9. Cleaning

Cleaning of the protective screens is recommended periodically.

Dry Cleaning

Therefore an optics anti-static brush is suitable or bleeding the screen with dehumidified, clean and oil-free compressed air.

Do not be clean the device by using mechanical tools

Wet Cleaning

For cleaning the protective screen use a clean, soft, lint-free cloth or lens cleaning paper with pure alcohol (isopropyl).

Never use standard glass cleaner or other cleaning agents.

10. Software Support with MEDAQLib

MEDAQLib offers you a documented driver DLL. This allows you to integrate sensors from MICRO-EPSILON in conjunction with a converter or interface module into existing or customer-specific PC software.

MEDAQLib

- contains a DLL that can be imported into C, C++, VB, Delphi and many additional programs,
- makes data conversion for you,
- works independent of the used interface type,
- features by identical functions for the communication (commands),
- provides a consistent transmission format for all MICRO-EPSILON sensors.

For C/C++ programmers MEDAQLib contains an additional header file and a library file. You will find the latest driver / program routine at:

www.micro-epsilon.com/service/download/

www.micro-epsilon.com/service/software-sensorintegration/medaqlib/

11. Disclaimer

All components of the device have been checked and tested for functionality in the factory. However, should any defects occur despite careful quality control, these shall be reported immediately to MICRO-EPSILON or to your distributor / retailer.

MICRO-EPSILON undertakes no liability whatsoever for damage, loss or costs caused by or related in any way to the product, in particular consequential damage, e.g., due to

- non-observance of these instructions/this manual,
- improper use or improper handling (in particular due to improper installation, commissioning, operation and maintenance) of the product,
- repairs or modifications by third parties,
- the use of force or other handling by unqualified persons.

This limitation of liability also applies to defects resulting from normal wear and tear (e.g., to wearing parts) and in the event of non-compliance with the specified maintenance intervals (if applicable).

MICRO-EPSILON is exclusively responsible for repairs. It is not permitted to make unauthorized structural and / or technical modifications or alterations to the product. In the interest of further development, MICRO-EPSILON reserves the right to modify the design.

In addition, the General Terms of Business of MICRO-EPSILON shall apply, which can be accessed under Legal details | Micro-Epsilon <https://www.micro-epsilon.com/impressum/>.

For translations into other languages, the German version shall prevail.

12. Service, Repair

If the sensor or sensor cable is defective, please send us the affected parts for repair or exchange.

If the cause of a fault cannot be clearly identified, please send the entire measuring system to:

MICRO-EPSILON Eltrotec GmbH
Manfred-Wörner-Straße 101
73037 Göppingen / Germany

Tel. +49 (0) 7161 / 98872-300
Fax +49 (0) 7161 / 98872-303
e-mail eltrotec@micro-epsilon.com
www.micro-epsilon.com

13. Decommissioning, Disposal

In order to avoid the release of environmentally harmful substances and to ensure the reuse of valuable raw materials, we draw your attention to the following regulations and obligations:

- Remove all cables from the sensor and/or controller.
- Dispose of the sensor and/or the controller, its components and accessories, as well as the packaging materials in compliance with the applicable country-specific waste treatment and disposal regulations of the region of use.
- You are obliged to comply with all relevant national laws and regulations.



For Germany / the EU, the following (disposal) instructions apply in particular:

- Waste equipment marked with a crossed garbage can must not be disposed of with normal industrial waste (e.g. residual waste can or the yellow recycling bin) and must be disposed of separately. This avoids hazards to the environment due to incorrect disposal and ensures proper recycling of the old appliances.
- A list of national laws and contacts in the EU member states can be found at https://ec.europa.eu/environment/topics/waste-and-recycling/waste-electrical-and-electronic-equipment-weee_en. Here you can inform yourself about the respective national collection and return points.
- Old devices can also be returned for disposal to MICRO-EPSILON at the address given in the imprint at <https://www.micro-epsilon.de/impressum/>.
- We would like to point out that you are responsible for deleting the measurement-specific and personal data on the old devices to be disposed of.
- Under the registration number WEEE-Reg.-Nr. DE28605721, we are registered at the foundation Elektro-Altgeräte Register, Nordostpark 72, 90411 Nuremberg, as a manufacturer of electrical and/or electronic equipment.

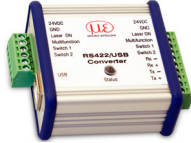

Appendix

A 1 Optional Accessories

PC1171-2 Power and output cable, 2 m long		For optoNCDT ILR series 1171 straight connector M12 plug 12-pin, 2m long with open ends
PC1171-5 Power and output cable, 5 m long		For optoNCDT ILR series 1171 straight connector M12 plug 12-pin, 5m long with open ends
PC1171-10 Power and output cable, 10 m long		For optoNCDT ILR series 1171 straight connector M12 plug 12-pin, 10m long with open ends
IF2001/USB		Converter from RS422 to USB, type: IF2001/USB, suitable for PC2250-x cable, including driver, Connections: 1x 10-pin socket strip (cable clamp), type: Würth 691361100010; 1x 6-pin socket strip (cable clamp), type: Würth 691361100006
PS2020		Power supply for DIN rail installation, input 230 VAC, output 24 VDC/2.5 A

A 2 Factory Settings

All parameters are reset to the factory settings except baud rate (BR), see A 3.6.2 and target selection (ST), see A 3.6.14.

Measure frequency (MF)	10000 (max 40000) Hz
Average value (SA)	1000
Measure window (MW)	-290.000 290.000 0
Trigger in (TI)	Internal trigger
Trigger out (TO)	Rising edge
Distance Offset (OF)	0.000
Error mode (SE)	1
Digital out (Q1)	0.000 1.000 0.050 1
Digital out (Q2)	0.000 1.000 0.050 1
Analog out (QA)	0.000 1.000
Receiver gain (GN)	0
Serial baud rate (BR)	115200
Serial output format (SD)	dec (0), value (0)

A 3 ASCII Communication with Sensor

A 3.1 General Information

The ASCII commands can be sent to the sensor via the RS422 or RS232 interface. All commands, inputs are in English. A command always consists of the command name and zero or more parameters that are separated with a space (0x20) and end in CR (0x0d). The response to unknown commands or faulty parameter formats is a "?" (0x3F).

Remember:

To be able to enter commands first stop measurement in sensor and output of data by pressing <ESC> key (0x1b).

Example: Ask about all parameter values:

PA<CR>

Example: Set average value to 100:

SA 100<CR>

Example: Ask about current average value:

SA<CR>

This might the show the value 100.

In the documentation of sensor commands we use the following conventions:

Parameters in [] brackets are optional and require you to enter the preceding parameter.

Successive parameters without [] brackets are required, i.e. no parameter can be omitted. Alternative entries for parameter values are separated by "|", e.g. the values "a", "b" or "c" can be set for "a|b|c". Parameter values in <> brackets can be selected from a value range.

A 3.2 Commands Overview

Group	Chapter	Command	Brief information
Identification			
	Chap. A 3.3.1	ID	ID Recognition
	Chap. A 3.3.2	ID?	Online Help
Operation Modes			
	Chap. A 3.4.1	DM	Single Distance Measurement
	Chap. A 3.4.2	DT	Continuous Distance Measurement
Status			
	Chap. A 3.5.1	TP	Internal Temperature
	Chap. A 3.5.2	HW	Hardware Status
	Chap. A 3.5.3	PA	Display Parameter Setting
	Chap. A 3.5.4	PR	Parameter Reset
Setup Parameters			
	Chap. A 3.6.1	AS	Autostart Function
	Chap. A 3.6.2	BR	Baud Rate
	Chap. A 3.6.3	DR	ILR1171 Restart (Device Reset)
	Chap. A 3.6.4	GN	Setup GAIN
	Chap. A 3.6.5	MF	Measurement Frequency
	Chap. A 3.6.6	MW	Measurement Window
	Chap. A 3.6.7	OF	Offset
	Chap. A 3.6.8	QA	Analog Output
	Chap. A 3.6.9	Q1/Q2	Switching Output
	Chap. A 3.6.10	SA	Mean Value Average
	Chap. A 3.6.11	SO	Set Offset
	Chap. A 3.6.12	SD	Data Format of Serial Interface Output
	Chap. A 3.6.13	SE	Error Mode
	Chap. A 3.6.14	ST	Select Target
	Chap. A 3.6.15	TC	Time Calibration
	Chap. A 3.6.16	TE	Terminator
	Chap. A 3.6.17	T1 + T0	Trigger
	Chap. A 3.6.17.1	TI	Trigger Input
	Chap. A 3.6.17.2	TO	Trigger Output
	Chap. A 3.6.17.3	AUTOTRIGGER	Continuous Distance Tracking Controlled by Trigger
	Chap. A 3.6.18	UB	Unit for Binary Output

A 3.3 Identification

A 3.3.1 ID Recognition

ID

When entering the command ID, the optoNCDT ILR1171 will respond by displaying the manufacturer's data in the following order: ID, serial number, firmware version.

Response: ID SN 180004 V3.38R 630

A 3.3.2 ID? - Online Help

ID?

By entering the command ID? the user will obtain an overview of all available operations and parameters described in the following sections.

Response:

Operation Mode

DM[Enter].....single distance
DT[Enter].....continuous distance

Status

TP[Enter].....internal temperature [°C]
HW[Enter].....hardware status
PA[Enter].....display parameter

Setup Parameter

PR[Enter].....reset parameter
DR[Enter].....reset device
AS[Enter]/ASs[Enter].....display/set autostart command
MF[Enter]/MFx[Enter].....display/set measure frequency
GN[Enter]/GNx[Enter].....display/set receiver gain
SA[Enter]/SAx[Enter].....display/set average value
MW[Enter]/MWx y z[Enter].....display/set measure window
OF[Enter]/OFx[Enter].....display/set distance offset
SO[Enter].....set current distance to offset
SE[Enter]/SEx[Enter].....display/set error mode
Q1[Enter]/Q1w x y z[Enter].....display/set digital out Q1
Q2[Enter]/Q2w x y z[Enter].....display/set digital out Q2
QA[Enter]/QAx y[Enter].....display/set analog out QA
BR[Enter]/BRx[Enter].....display/set serial baud rate
SD[Enter]/SDx y[Enter].....display/set serial output format
UB[Enter]/UBx[Enter].....display/set unit for binary output
TE[Enter]/TEx[Enter].....display/set serial terminator
ST[Enter]/STx[Enter].....display/set first or last target for output
TC[Enter]/TCx[Enter].....display/set DT recalibration timing x in sec (0 off)
TI[Enter]/TIx y[Enter].....display/setup input trigger
T0[Enter]/T0x y[Enter].....display/setup output trigger

A 3.4 Operation Modes

• The sign ESC (1Bh) finishes the data output. Now the sensor waits for a new command.

↓

A 3.4.1 DM - Single Distance Measurement

DM

The sensor performs one measurement and then waits for new commands.

The duration of the measurement depends on the number of preset measuring values SA , see A 3.6.10 and the preset measuring frequency MF , see A 3.6.5.

A 3.4.2 DT - Continuous Distance Measurement (Distance Tracking)

DT

The sensor performs a continuous measurement.

The measurement can be interrupted by command:

ESC (Escape) = 0x1B

The measurement output frequency is determined by the number of preset measuring values SA , see A 3.6.10, the preset measuring frequency MF , see A 3.6.5 and the data format of serial output SD , see A 3.6.12.

Parameter baud rate is important for the data transfer.

Example response (SD 0 3 setting): D 0002.935 21.1 57.2

Output format = decimal (D)

Distance = 2.935 m

Signal quality = 21.1

Temperature = 57.2 °C

- The output frequency of DT depends baud rate BR , see A 3.6.2.
- ! If the baud rate is too low not all measured values can be output / displayed.

A 3.5 Status

A 3.5.1 TP - Internal Temperature

TP

Output of the internal temperature of the device in °C.

- The internal temperature of the device is not the same as the operating temperature stated under Technical Data, see 3.3.
- ! The internal temperature will be approximately 25 Kelvin higher as the ambient temperature.

Response (example):

TP 048.4

- The user of the optoNCDT ILR1171 must make sure that the stated ambient temperature (operating temperature) is adhered to. In case of deviations below or above the temperature range no measurement is possible. The optoNCDT ILR1171 will send an error message.

A 3.5.2 HW - Hardware Status

HW

A device-specific list of parameters and measurements is shown.

All parameters are internal information regarding the hardware status, changes are not possible.

Example:

```
Temp (Board)    45.0 °C
Laser voltage   25485 mV
Measure Result  0
```

Explanation of the hardware status items:

Error code	Fault indication
Temp (Board)	Temperature of the controller, internal
Laser-Voltage	Supply voltage laser diode driver
Measure Result	Classification of measurement conditions, information to source of error message 0 - measurement o.k. 1 - out of measurement window 2 - invalid pulse width 3 - small pulse width 4 - distance out of range 5 - noise pulses detected 6 - no pulses

A 3.5.3 PA - Display Parameter Setting

PA

Output of a parameter list with the current settings

Response:

```
measure frequency[MF].....500 (max40000) Hz
average value[SA].....2
measure window[MW].....-290.000 290.000 0
trigger in[TI].....internal trigger
trigger out[TO].....rising edge
distance offset[OF].....0.000
error mode[SE].....1
digital out[Q1].....0.000 1.000 0.050 1
digital out[Q2].....0.000 1.000 0.050 1
analog out[QA].....0.000 1.000
receiver gain[GN].....0
serial baud rate[BR].....115200
serial output format[SD].....dec (0), value+amplitude (1)
unit for binary output[UB].....1000.000
serial output terminator[TE].....0Dh0Ah (0)
autostart command[AS].....DT
select target[ST].....0/first
recalibration timing[TC].....1 sec/enabled
```

A 3.5.4 PR - Parameter Reset

PR

All parameters are reset to the factory settings except baud rate (BR), see A 3.6.2 and target selection (ST), see A 3.6.14.

Response:

```
measure frequency[MF].....10000 (max40000) Hz
average value[SA].....1000
measure window[MW].....-290.000 290.000 0
trigger in[TI].....internal trigger
trigger out[TO].....rising edge
distance offset[OF].....0.000
error mode[SE].....1
digital out[Q1].....0.000 1.000 0.050 1
digital out[Q2].....0.000 1.000 0.050 1
analog out[QA].....0.000 1.000
receiver gain[GN].....0
serial baud rate[BR].....115200
serial output format[SD].....dec (0), value (0)
unit for binary output[UB].....1000.000
serial output terminator[TE].....0Dh0Ah (0)
autostart command[AS].....DT
select target[ST].....0/first
recalibration timing[TC].....1 sec/enabled
```

A 3.6 Setup Parameters

Transfer of the settings to the optoNCDT ILR1171: Command+terminator 0x0D (ENTER)

In case of commands with one parameter, that parameter is entered directly or separated by a space (0x20).

In case of commands with several parameters, those are separated from each other by a space (0x20).

A 3.6.1 AS - Autostart Function

AS

The autostart function determines what the optoNCDT ILR1171 does after a cold start.

Upon connection to the supply voltage and after the internal switch-on routine, the optoNCDT ILR1171 carries out the command automatically and sends the data to the available outputs.

Request	AS
Set	ASx
Parameter value range x	BR, DM, DT, HW, ID, ID?, MF, MW, OF, PA, PR, Q1, Q2, QA, SA, SE, SD, TE, TP
Standard	DT

The period of time between switching on the supply voltage and the output of the first measured value is max. 750 ms (if SA=1); SA, see A 3.6.10.

A 3.6.2 BR - Baud Rate

BR

Enables the adjustment of the serial baud rate x.

As soon as a new baud rate has been set, the device will immediately start to communicate based on that new baud rate.

Request	BR
Set	BRx
Parameter value range x	9600, 19200, 115200, 230400, 460800, 921600, 1843200, 2000000
Standard	115200 bauds

i Setting a very high baud rate implies a risk. Some computers are unable to support a baud rate of 460 800. for example. If the baud rate is set via the command `BR460800`, communication will no longer be possible without an interface converter, i.e. it will be impossible to reset the baud rate to a lower value without any auxiliary means!

Example:

Input: BR 9600

Output: BR 9600

A 3.6.3 DR - ILR1171 Restart (Device Reset)

DR - optoNCDT ILR1171 (Device Reset)

DR executes a cold start of the optoNCDT 1171 and practically simulates a voltage interruption. This command is useful when the autostart command has been changed.

Response:

Reset device

wait...<0>

➡ Continue with execution of command in parameter AS, see A 3.6.1.

A 3.6.4 GN - Setup GAIN

GN

Parameterizes the amplification of the receiver channel.

Request	GN
Set	GNx
Parameter value range x	-1 = automatic GAIN 0, 1, 2 or 3 = selected GAIN with fixed amplification
Standard	0

Example:

Input: GN - 1

Output: GN - 1

i GN - 1 Automatic control of amplification depending on the received light
 GN - 0 Optical amplification value for most applications
 GN 1, 2 or 3 Higher amplification value as GN 0

Advantage of GN > 0: Measurements on targets with low reflectivity are possible

Disadvantage of GN > 0: More interference pulses will cause a lower accuracy of the output values

A 3.6.5 MF - Measurement Frequency

MF

Parameterizes the number x of single pulses to be transmitted per second.

Request	MF
Set	MF x
Parameter value range x	1 ... 40000; resolution: 1
Standard	10000

Example:

Example:

Input: MF 1000

Output: MF 1000 HZ

For example, MF 1000 means that 1000 single laser pulses are transmitted per second.

The realizable output frequency depends on the following parameters:

- Interface solution (e.g. serial interface RS232 or RS422; analog output)
 - Length of the interface cable
 - Transfer speed (baud rate)
 - Average (parameter SA)
 - Data format of output value (binary, decimal → parameter SD)
 - Number of output values (distance/ signal strength/ → temperature parameter
- The default value of SA is 1000. This means that 1000 measurements are necessary for 1 output-value.
 ⓘ This procedure extends the measurement time.
 Example: With parameter MF 1 and SA 1000 every 1 second will be started a measurement; but the output time for 1 value is about 17 min.
- The baud rate BR will be responsible for the limitation of the output frequency.
 ⓘ Please check the dependence of measuring frequency/ output frequency with baud rate and data format of serial interface output (SD) in the tables below.
 If measuring frequency will be higher as the values in the table some measured values will be lost.
 Please double check with a new setting of measuring frequency MF the BR setting.

Binary output

Output values	Distance	Distance + signal quality	Distance + temperature	Distance + signal quality + temperature
Length of output data (Byte)	2	3	3	4
Output data format	SD 2 0	SD 2 1	SD 2 2	SD 2 3
Baud rate	Maximum output frequency = MF max (Hz)			
9600	470	300	300	220
19200	900	600	600	450
115200	5750	3800	3800	2880
230400	11600	7700	7700	5800
460800	23200	15500	15500	11600
921600	40000	30300	30300	23000
2000000	40000	40000	40000	34000

Decimal output

Output values	Distance	Distance + signal quality	Distance + temperature	Distance + signal quality + temperature
Length of output data (Byte)	11	16	17	22
Output data format	SD 0 0	SD 0 1	SD 0 2	SD 0 3
Baud rate	Maximum output frequency = MF max (Hz)			
9600	80	50	48	40
19200	160	100	90	75
115200	1000	700	660	480
230400	2000	1400	1300	980
460800	4100	2750	2500	1850
921600	7300	4750	4350	3300
2000000	12200	7850	6480	5000

A 3.6.6 MW - Measurement Window

MW

This is for parameterizing the range of a measurement window, starting with x and terminating with y.

Parameter z set the output value before and after the range of measurement window (MW).

Only those measured values are put out which are within the range of the measurement window.

For example, the measurement window can be used to:

- Blank out interfering objects before and behind a measurement range
- Determine a defined measurement range

An object detected before or behind the measurement window will generate the output of an invalid measured value.

Request	MW
Set	MWx y
Parameter value range x	float32; resolution: 0.001
Parameter value range y	float32; resolution: 0.001
Standard	-5000.000 ... 5000.000

Output: MW -71.000 71.000 0

The optoNCDT ILR 1171 does not perform a plausibility check of the preset measurement window. It is responsibility of the user to set the correct parameters.

Output values

	Measuring window		
	Distance < x	x < Distance < x	Distance > y
z = 0	DE02	Measuring value	DE02
z = 1	No output/ blanking pulse	Measuring value	No output/ blanking pulse

A 3.6.7 OF - Offset

OF

The command parameterizes a user-adapted offset x, which is added to the measured value.

Request	OF
Set	OFx
Parameter value range x	float32; resolution: 0.001 (-250.000m ... +250.000m; resolution 1mm = 0.001m)
Standard	0.000

Output: OF 0.000

The optoNCDT ILR1171 does not perform a plausibility check of the preset offset. It is the responsibility of the user to set the correct parameters.

A 3.6.8 QA - Analog Output

QA

The analog output enables standardized analog distance data transfer over long distances by means of a two-wire line. The current of 4 ... 20 mA impressed in the line is proportional to the measured distance within an adjustable distance interval. Parameterization is done via the serial interface.

The current to be put out in case of faulty measurements is parameterized via the command `SEX`.

Analog output properties:

- 4 ... 20 mA
- Indication in case of error: 3 mA or 21 mA (selectable via parameter `SE`, see A 3.6.13) or last measured value
- Resolution: 16 bit DA converter

If current/voltage is to be converted, there must be a load resistor of < 500 Ohms/0.5 W (12 V of internal voltage → max. measuring current of 0.024 A) between current output `QA` and GND.

Value	Description	Specification
x	Lower limit	$x \neq y$
y	Upper limit	$y \neq x$

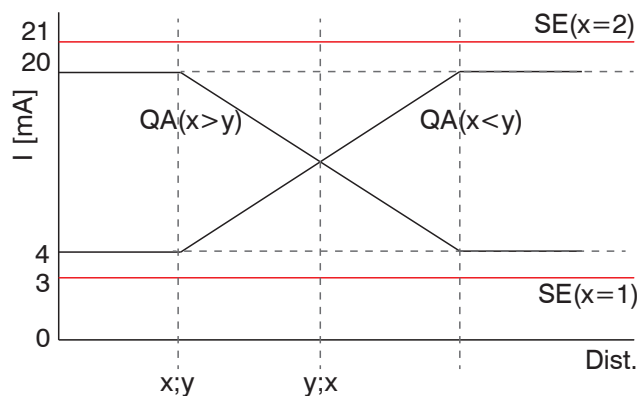

Fig. 20 Analog output

The lower limit value can be lower or higher than the upper limit value; the current range will invert accordingly.

Entries of identical limit values will be ignored and not be transferred.

Request	QA
Set	QA x y
Parameter value range x	float32; resolution: 0.001
Parameter value range y	float32; resolution: 0.001
Standard	0.000 1.000

The optoNCDT ILR1171 does not perform a plausibility check of the QA settings. It is responsibility of the user to set the correct parameters.

• The measurement window `MW`, see A 3.6.6, applies to the analog output as well.

The output current (in mA) is calculated as follows:

$x < y$	$QA[mA] = 4 \text{ mA} + 16 \text{ mA} * \frac{Dist - x}{y - x}$
$x > y$	$QA[mA] = 20 \text{ mA} - 16 \text{ mA} * \frac{Dist - y}{x - y}$

Dist. = Measuring distance

• Please do not use the analog output for fast processes with high distance changes.
 ⓘ The typical settling time for a jump between 4 mA and 20 mA will be 40 μ s.

A 3.6.9 Q1/Q2 - Switching Output

Q1/Q2

Q1/Q2 parameterizes the behavior of the switching outputs.

Switching outputs Q1 and Q2 show the distance information as logical switching information. They signalize whether the preset hysteresis switching range is exceeded or fallen short of.

Thus, they are ideally suitable for direct further processing of monitored values such as fill level or object detection. Parameterization is done via the serial interface.

The parameters include the beginning w of the measuring range when the output switches, the length x of the measuring range, the hysteresis y as well as the logic behavior z.

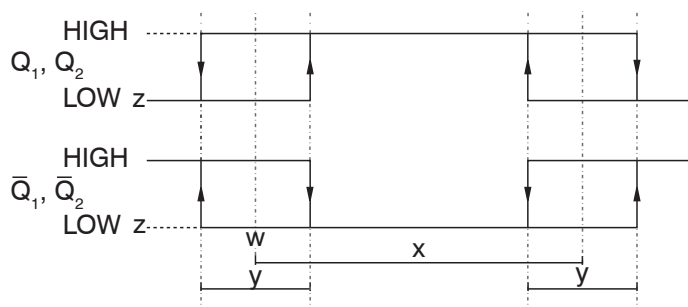

Low = 0 U < 1 V

High = 1 U = Operating voltage - 1 V

Fig. 21 Switching behavior of Q1 or Q2 respectively

Variable	Description	Specification
w	Switching threshold	-9999,999 ... +9999,999
x	Switching range	x > 0; x > y
y	Switching hysteresis	y ≥ 0
z	Switching state	z = 0 or 1

Request	Q1 or Q2
Set	Q1w x y z or Q2w x y z
Standard	float32; resolution: 0.001

The optoNCDT ILR1171 does not perform a plausibility check of Q1 or Q2 settings respectively.

A 3.6.10 SA - Mean Value Average

SA

Parameterizes the number x of single measured values to be averaged for one measurement. SA directly correlates with the measurement frequency MF, see A 3.6.5.

Request	SA
Set	SAx
Parameter value range x	32 bit integer; resolution: 1
Standard	1000

The dispersion of the measured values can be reduced by calculating the mean value.

$$\sigma_{SA} = \frac{\sigma_1}{\sqrt{SA}}$$

σ_{SA} Dispersion after mean value determination from several distance measurements

σ_1 Dispersion of single measured value (± 60 mm)

SA Mean value

Example:

For table below applies:

Measuring frequency 15 kHz and output frequency 15 kHz will be achieved with following parameters:

Baud rate 921.600 / binary output

Measurement frequency MF (Hz)	Mean value SA	Output frequency (Hz)	Dispersion (mm)
15000	1	15000	±60
15000	10	1500	±19
15000	100	150	±6
15000	1000	15	±2

• For SA will be used all valid measured distance values. If distance is out of the measurement window MW the measured value will ignored for the SA calculation.

A 3.6.11 SO - Set Offset

SO

SO carries out a single distance measurement and sets it as - OF (offset). SO can only be executed and is not really a parameter.

SO can be used for zero adjustment of distances in systems or processes.

• Please note the interaction of parameter MW , OF, SO.

A 3.6.12 SD - Data Format of Serial Interface Output

SD

Parameterizes the output format n and the output values m.

Request	SD
Set	SDn m
Parameter value range n	0, 1, 2
Parameter value range m	0, 1, 2, 3
Standard	0 0

Example:

Input: SD 03

Output: SD 03

n	Output format	m	Output values
0	Decimal	0	Distance
1	Not available	1	Distance + signal quality (not available for binary)
2	Binary	2	Distance + temperature (not available for binary)
		3	Distance + signal quality + temperature (not available for binary)

• Output format 1 (hexadecimal) is not available!

• For binary output distance value is available only (not temperature and/ or signal quality).

• In conjunction with the baud rate, the output format determines the maximally possible output speed of measured values. If a higher measurement frequency is set, the results of some measurements will not be put out.

A 3.6.13 SE - Error Mode

SE

Parameterizes the behavior x of switching outputs Q1 and Q2 and of analog output QA in case of faulty measurements as well as the state after carrying out a single distance measurement.

Request	SE
Set	SE x
Parameter value range x	0, 1 or 2
Standard	1

x	Q1, Q2 ($z = 0$)	Q1, Q2 ($z = 0$)	QA
0	Last value	Last value	Last value
1	High	Low	3 mA
2	Low	High	21 mA

Low: $V < 1 V$

High: $V = \text{operating voltage} - 1 V$

The optoNCDT ILR1171 does not perform a plausibility check of the preset error mode.

A 3.6.14 ST - Select Target

ST defines the target which should be detected. The optoNCDT ILR1171 is able to detect 4 different target in maximum. Selection will be done between the first or the last detected target.

First target - Target next to the optoNCDT ILR1171

Last target - Last detected target

Output will be the distance of the defined target.

Request	ST
Set	ST x
Parameter value range x	0 (first target) or 1 (last target)
Standard	0

Example: Output: ST 0

• Parameter MW (measurement window) and SA (mean value, average) will influence the output. If the selected target will be outside of the range of measurement window the output will be not a distance values. → Please see setting of MW parameter z , see A 3.6.6.

A 3.6.15 TC - Time Calibration

Parameterizes the time between 2 customized calibrations.

The calibration is necessary to stabilize the distance accuracy and to avoid a lower accuracy because of temperature changed in the environmental of the electronic parts.

Request	TC
Set	TC x
Parameter value range x	0 (no calibration), 1 ... 3660 (seconds) (= 1 sec up to 1 h interval)
Standard	0

Up to a measuring frequency of approx. 35 kHz the calibration will be done without any influences of the output frequency.

Between 35 kHz and 40 kHz it could be possible that the data output will interrupt for one (1) distance output every x seconds ($x =$ parameter of TC).

A 3.6.16 TE - Terminator

Sets the terminator for the output of measured values in ASCII format, see also command `SD`, see A 3.6.12

Request	TE
Set	TEnn
Parameter value range x	0 ... 9
Standard	0

Example:

Input: TE 1

Output: TE 1

nn	ASCII	Meaning
0	0x0D 0x0A	CR LF
1	0x0D	CR
2	0x0A	LF
3	0x02	STX
4	0x03	ETX
5	0x09	HTab
6	0x20	Space
7	0x2C	Single quote
8	0x3A	Colon
9	0x3B	Semicolon

When an invalid character is entered, it will not be set. The previous terminator will be maintained.

A 3.6.17 TI + TO Trigger

Trigger function

The optoNCDT ILR1171 trigger could be used as input or output.

- Trigger input / external trigger function:
External trigger signal will be sent → start of measurement `DM` in accordance with parameter `TI`.
- Trigger output / e.g. connection between 2 sensors:
The output trigger signal of the 1. LUMOS (parameterized with `TO`) starts a single measurement `DM` of the second LUMOS (parameterized with `TO`).
- Continuous distance tracking controlled by trigger.

Differences between trigger input and trigger output

Important is the parameter `y` of `TI` and `TO`.

$TI_y > 0 / TO_y = 0$ Trigger input
The measurement starts after an external trigger impulse.

$TI_y = 0 / TO_y > 0$ Trigger output
optoNCDT ILR1171 sends a trigger impulse to the second device.

The parametrization of the trigger connection is carried out via the serial interface or the internal display.

i For the trigger function may only be activated `TI` or `TO`. A concurrent use of `TI` and `TO` is not possible → output of warning information w1907.

Voltage levels for the trigger signals

Low level	0 - 1.5 V
High level	3 - 30 V
Threshold	2.25 V
Hysteresis	0.1 V

A 3.6.17.1 TI - Trigger Input

TI

The parametrization of trigger input will be set with command TI.

x	Edge	Parameterized the edge of trigger signal and start and stop for “Autotrigger function”
	0	Rising edge (from LOW to HIGH)
	1	Falling edge (from HIGH to LOW)
	2	Every edge
	3	Start or stop of Autotrigger with rising edge
	4	Start or stop of Autotrigger with falling edge
y	Delay	Parameterized the time (delay) up to the measurement in milliseconds msec

Request	TI
Set	TIx y
Parameter value range x	0, 1, 2, 3, 4
Parameter value range y	0 to max 60 000 msec (equal to 1 minute)
	active: from 1 msec upward
	disabled: 0 msec
Standard	0 0

Example: Trigger (input) [TI]: 0, 0

i Maximum frequency of external trigger signal for Trigger IN (TI): 30 kHz

If the trigger frequency is too high, no measurement value can be determined. The output is E02. The trigger frequency must be reduced.

A 3.6.17.2 TO - Trigger Output

TO

The parametrization of trigger output will be set with command TO.

x	Edge	Parameterized the edge of trigger signal
	0	Rising edge (from LOW to HIGH)
	1	Falling edge (from HIGH to LOW)
	2	Every edge

Request	TO
Set	TOx y
Parameter value range x	0, 1, 2
Standard	0

Example: Trigger (output) [TO]: 0

i Maximum frequency of Trigger OUT (TO) = MF (Measurement frequency)

A 3.6.17.3 AUTOTRIGGER Function - Continuous Distance Tracking Controlled by Trigger

AUTOTRIGGER

The parametrization of AUTOTRIGGER function will be set with command TI.

The first trigger signal starts the command which is defined in AUTOSTART (command AS) the second trigger signal will stop the process.

x	Edge	Parameterized the edge of start or stop of AUTOTRIGGER signal
	3	Start or stop of AUTOTRIGGER with rising edge
	4	Start or stop of AUTOTRIGGER with falling edge
y	Delay	Parameterized the time (delay) up to the measurement in milliseconds msec

Request	TI
Set	TIx y
Parameter value range x	3, 4
Parameter value range y	0 to max 60 000 msec (equal to 1 minute)
	active: From 1 msec upward
	disabled: 0
Standard	0 0

Example:

AS DT

TI 3 10

First trigger signal starts a continuous measurement (DT) with the rising edge. The delay between the trigger signal and start of measurement is 10 msec.

Next trigger signal stops a continuous measurement (DT) with the rising edge. The delay between the trigger signal and stop of measurement is 10 msec.

A 3.6.18 UB - Unit for Binary Output

UB

UB parameterized the resolution (in bit) for distance values in binary format (in mm).

Request	UB
Set	UBx
Parameter value range x	float32; resolution: 0.001
Parameter value range y	0 to max 60 000 msec (equal to 1 minute)
Standard	1000.000

Example:

Input: UB 2.5

Output: UB 2.500

This parameter influences all measurement outputs in binary format independent of the measuring frequency.

The binary output format will be set with parameter SD.

Example:

UB 0.001 → Resolution 1 μm

UB 1.000 → Resolution 1 m

UB 1000.000 → Resolution 1 mm (standard)

The measuring range will be depicted with 14 signed bits.

Distance value (binary) = Distance (mm) / UB

Distance range (binary): $-8192 \leq \text{Distance} \leq 8191$

i If the distance value is below or above the distance range, the binary output is 0.

A 3.7 ASCII Error Messages

In case of one or more detected errors, the error code with the highest index will be outputted (most serious defect/error).

Example:

```
No distance value identified, no other error    DE02
No distance value identified, in addition      DE06
```

Non-critical errors will be reset automatically, a critical error requires a device reset, see Fig. 22, command DR or power off/ on.

Hardware errors generate error code DE04.

Error Code	Description	Reset
DE02	No distance identified	Automatically, with the next measuring value
DE04	Device error (hardware)	Not automatic, device reset necessary
DE06	Temperature out of range	Automatically, if measured temperature is in the specified range
DE10	Internal laser voltage lower than the defined minimum voltage (ULaserMIN)	Not automatic, device reset necessary

Fig. 22 Error Codes

In binary format all errors will be sent as "0" (00).

The described error codes will be outputted, if an error is detected during

- optoNCDT ILR1171 measurement (DM, see A 3.4.1, DT, see A 3.4.2)
- a measuring mode (DM, see A 3.4.1, DT, see A 3.4.2) will be started.

Output of error message (like output of measuring values):

- once for measuring mode DM
- in the specified output frequency for measuring mode DT

The measuring mode DT could be stopped with <ESC> in the case of error and error message output too.

The communication with optoNCDT ILR1171, e.g. parameterizing, reset or start of new measurement, will be not influence by the error message.

If DT is started and the error did not reset automatically, the error message will be outputted again.

- The temperature (check with command TP, see A 3.5.1) may be higher than the ambient temperature.
- ! Approx. 30 min after power ON the measured temperature could be 25 Kelvin higher than ambient temperature.



MICRO-EPSILON Eltrotec GmbH
Manfred-Wörner-Straße 101 · 73037 Göppingen / Germany
Tel. +49 (0) 7161 / 98872-300 · Fax +49 (0) 7161 / 98872-303
eltrotec@micro-epsilon.com · www.micro-epsilon.com
Your local contact: www.micro-epsilon.com/contact/worldwide/

X9751466-A012053HDR
© MICRO-EPSILON MESSTECHNIK