

Data Sheet for Joysticks

Finger Joystick

Series TRY21



- 3-axis joystick with rotatable handle
- Space-saving design, exceptionally low profile above panel
- Contactless and reliable, wear-free Hall sensor technology
- Redundant output signals optional
- Protection IP54

The joysticks of the TRY21 series are unique in their size class on the market thanks to their rotatable knob, which, as a z-axis, enables an additional third, proportional degree of freedom in the application. This makes the TRY21 the smallest fingertip joystick with z-axis. The high-quality haptics convey a secure operating feel and enable the user to precisely control movements in up to three dimensions.

Technical Data

Sensor	Hall Effect
Supply Voltage	5 ± 0.5 VDC transient-free
Independent Linearity Tolerance	±3 % full scale
Return to Center Voltage	±250 mV
Expected Life	≥ 1 million cycles
Output Voltages	0 to 5 V / 0.5 to 4.5 V / 0.25 to 4.75 V
Currents	ca. 6 mA per axis
Impedance	>10 kOhm (>100 kOhm recommended)
Insulation Resistance	>100 MOhm at 250 VAC
Dielectric Strength	1 minute at 250 VAC
Mechanical Angle of Movement X-, Y-Axis	30° (±15° from center)
Mechanical Angle of Movement Z-Axis	60° (±30° from center)
Operating Force X-Y-Axis	approx. 1.5 N (from center), approx. 3.5 N (full deflection), max. 50 N
Operating Torque Z-Axis	approx. 10 mNm (from center), approx. 30 mNm (full deflection)
Operating Temperature	-20 °C to +60 °C
Storage Temperature	-20 °C to +65 °C
Sealing (above panel)	IP54
Vibration	10 to 55 Hz, 98 m/s ² (10 g)
Shock	294 m/s ² (30 g)
EMC	50 V/m (80 MHz..1 GHz 1 kHz 80% AM, IEC/EN61000-4-3)
ESD	IEC/EN61000-4-2, 5 kV

Data Sheet for Joysticks

Finger Joystick

Series TRY21

Please contact us for information regarding stock articles, delivery times and minimum order quantities.

Order Code

Description	Selection: standard=black/bold , possible <i>options=grey/italics</i>							
Series	TRY21							
Axes: 3 Axes		3						
Sealing: Rubber Boot			5					
Return Mechanism: Spring Return				1				
Handles: Handle Type A					A			
Limiters: Square Limiter						3		
Output Signal: 0.5 to 4.5 V <i>0.25 to 4.25 V</i> <i>0 to 5.0 V (rail to rail)</i>							1 2 3	
Signal Options: Single Output <i>Dual Output, parallel signals</i> <i>Dual Output, crossed signals</i>								0 1 2

For higher quantities or on-going demand, additional options are available

For example:

- Customer-specific cables
- Custom handle shapes and colour

Limiters



Square - Option "3"

Data Sheet for Joysticks

Finger Joystick

Series TRY21

Technical Drawings

Handle A

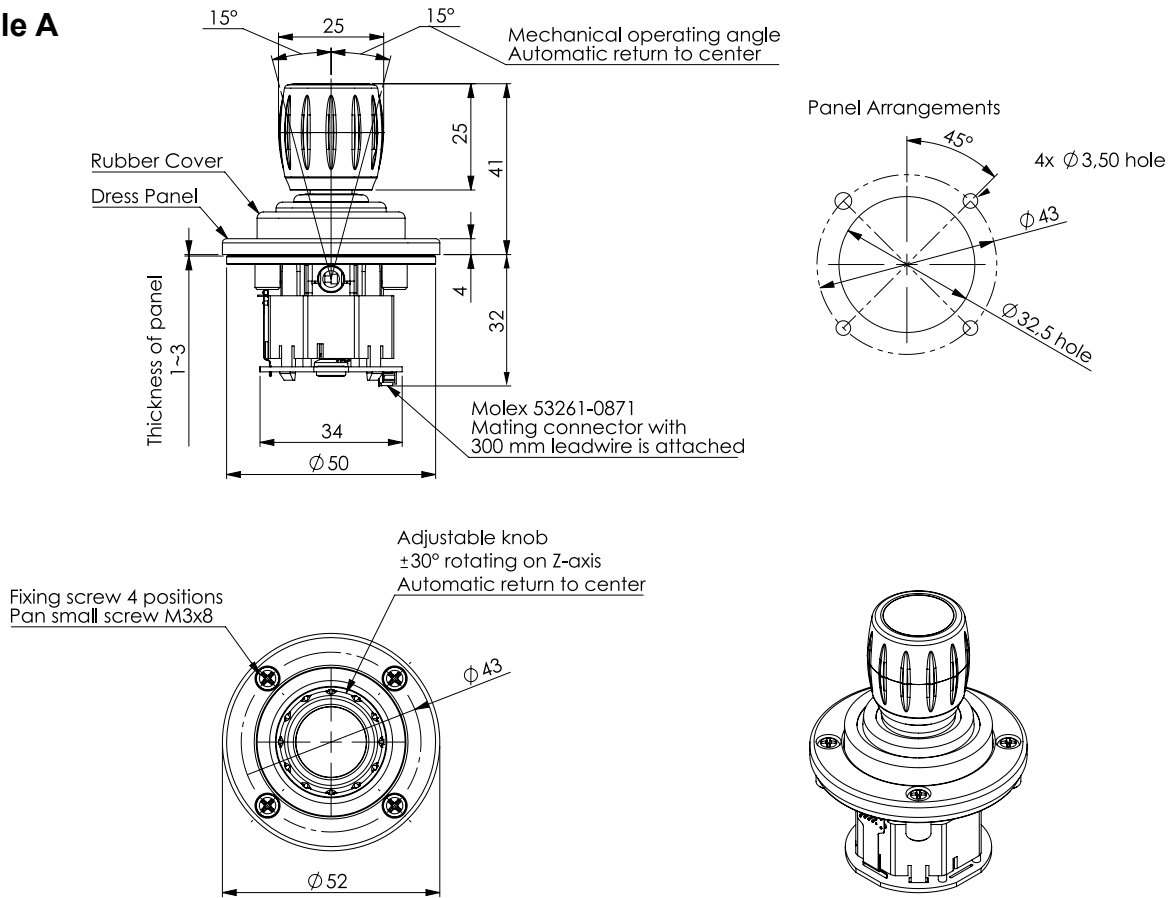

All Dimensions in mm

Wiring

Pin	Function	Colour
1	Supply +5 VDC	brown
2	X-Axis	red
3	X-Axis Dual Output	orange
4	Y-Axis	yellow
5	Y-Axis Dual Output	green
6	Z-Axis	blue
7	Z-Axis Dual Output	purple
8	Ground	grey

Termination: wires AWG28, length ca. 300 mm. They are connected to the joystick housing via MOLEX 51021-0800 connector. Included in delivery.

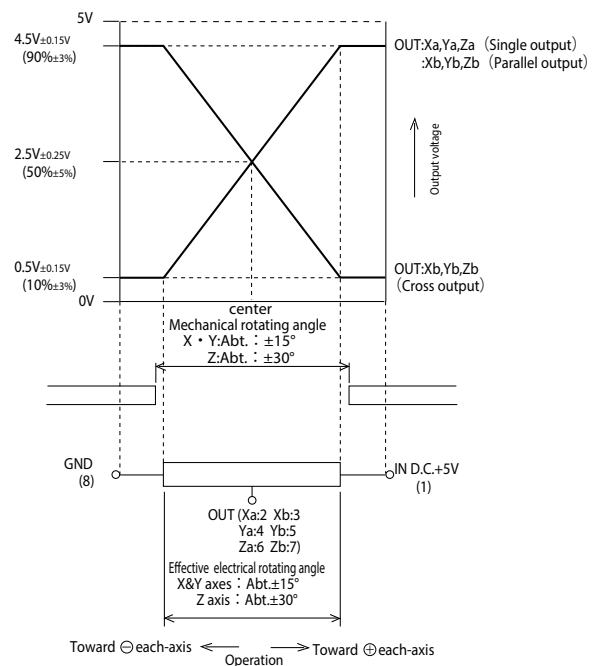

Note1 : The number in () shows connector number.
 Note2 : In (1) and GND (8) are shown in main circuit board.